

# Open Cloud Connect

**Cloud Services Architecture, SDN, NFV, and  
Management**

---

*Mehmet Toy, Ph.D*  
*Comcast*  
*January, 2016*  
*CL ETSI NFV Meeting*



# Outline

- **OCC Reference Architecture Fundamentals**
- **Cloud Service Actors**
- **Cloud Service Architectures: Interfaces and Connections**
- **Common Attributes of Cloud Services**
- **OCC vs ETSI NFV Architectures**
- **Mapping Between OCC and NFV Interfaces**
- **Cloud Services Management Architecture**
- **Open Cloud Project Test Bed**
- **What is Next?**

# OCC Reference Architecture Fundamentals

- ***Cloud Services provided over a Cloud Service Connection (cSC)***
- ***cSC is a logical entity that may ride over overlay, virtual and physical entities that are provided by single or multiple operator (s)***
- ***Cloud Service can include application entities, cSC and associated resources, as well as just the application or just the connection***
- ***User interface can be L1, L1-L2, L1-L3, L1-L7***
- ***Service frames (packets) can be Ethernet, IP packet, MPLS packet, application PDU***

# Cloud Service Actors

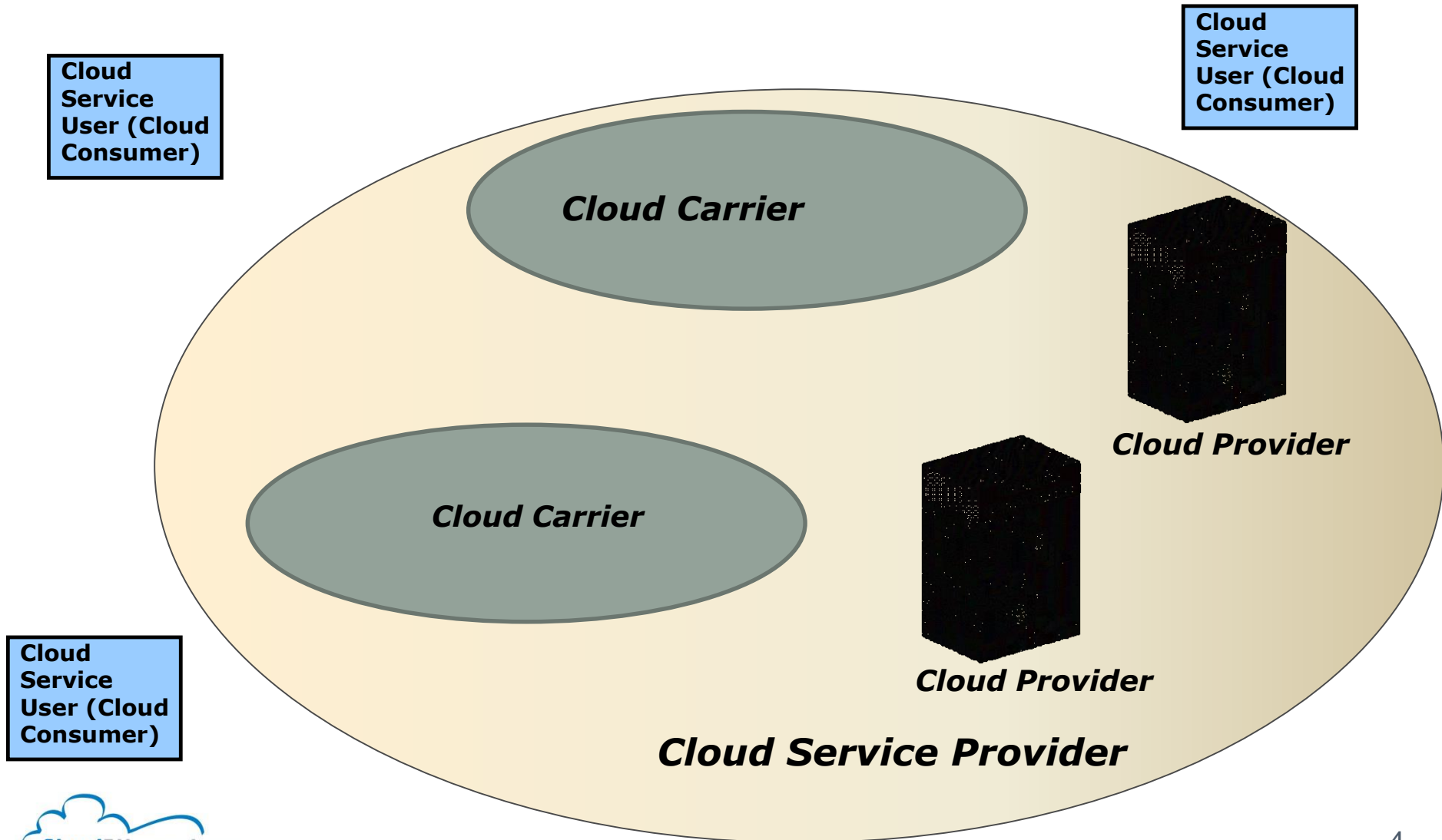

# Cloud Services

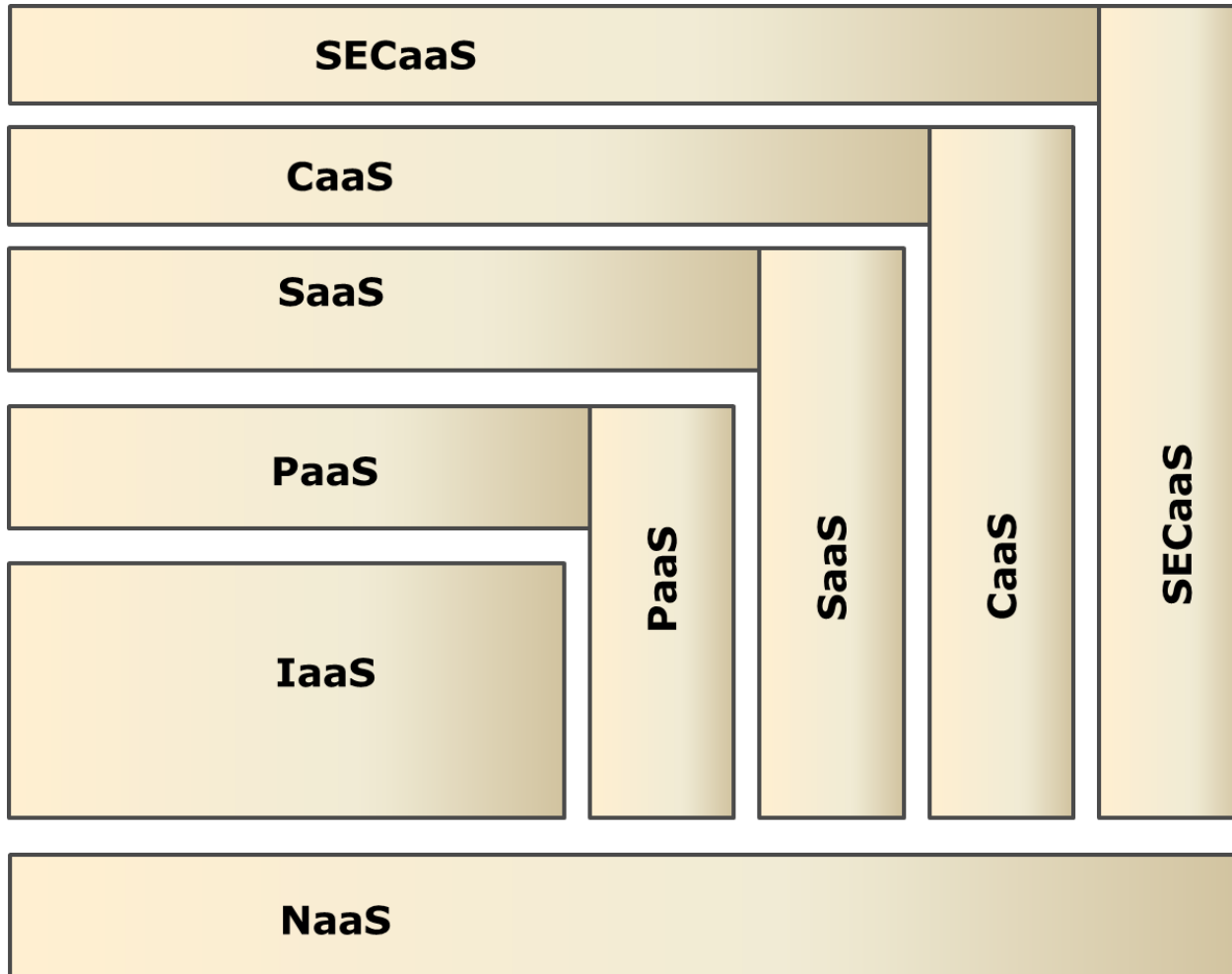

# Architecture for Cloud Services by one Operator

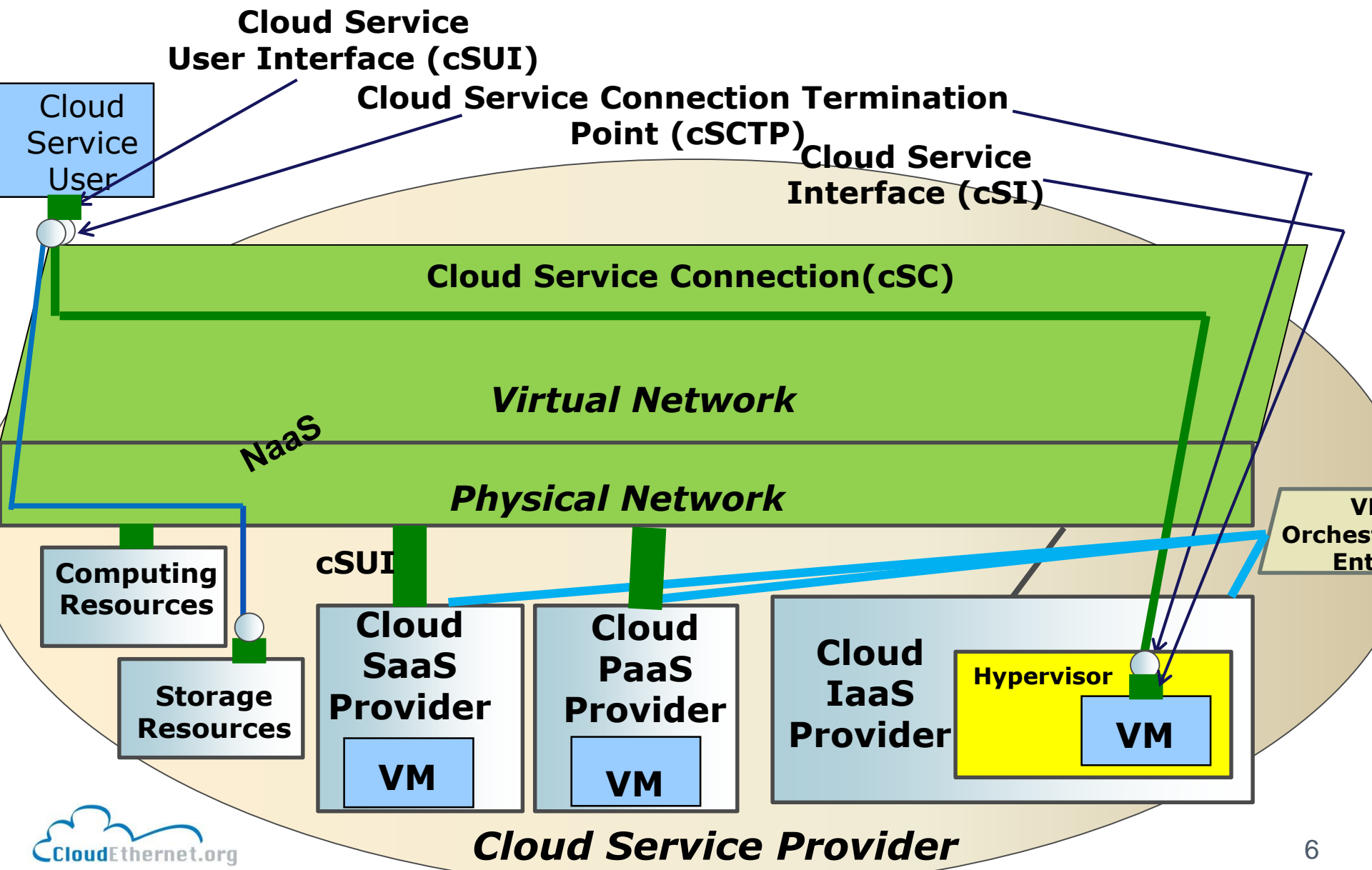

# Architecture for Cloud Services by Two Operators

cCcPI= Cloud Carrier Cloud Provider Interface

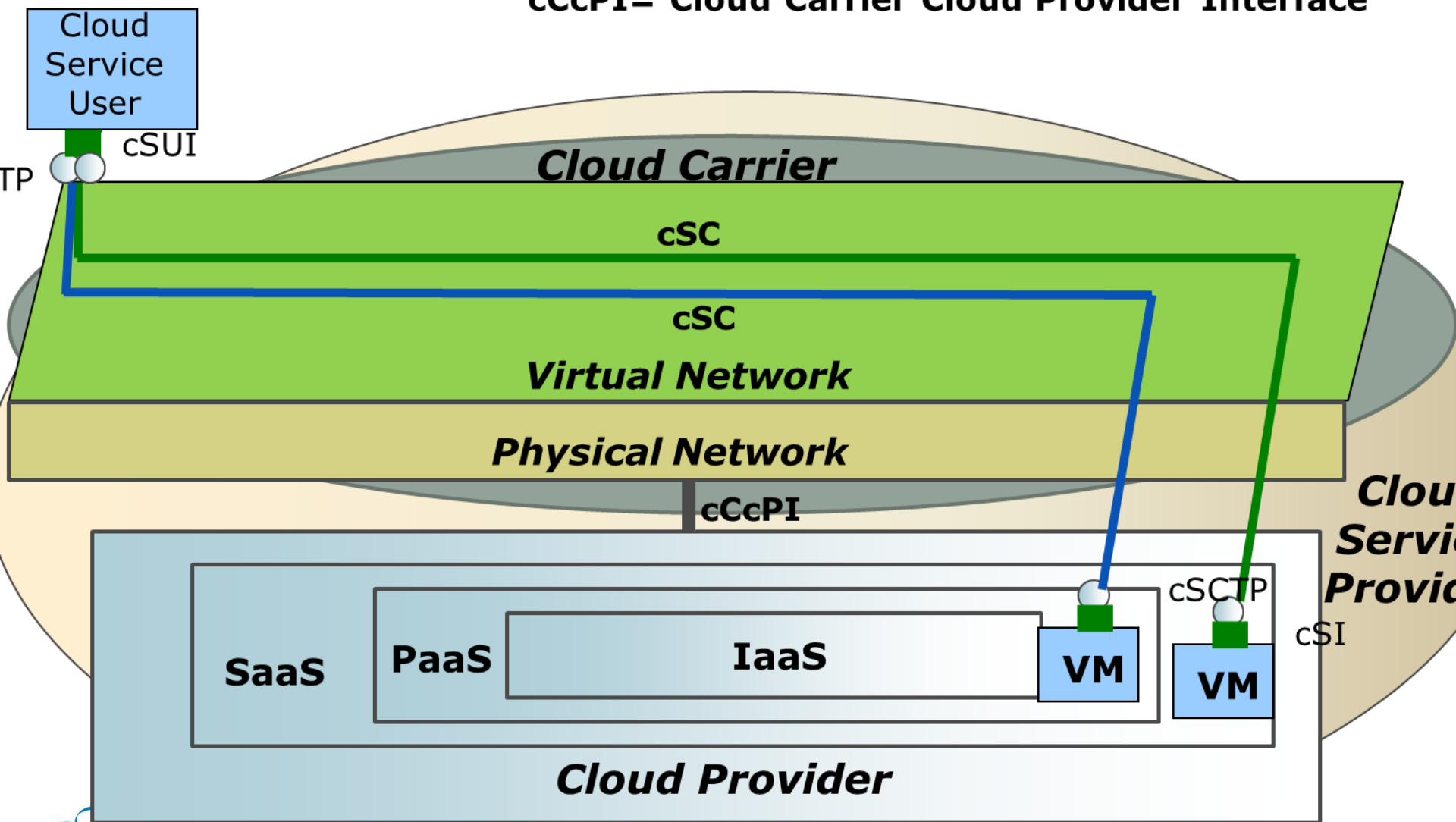

# Cloud Services Between Cloud Providers

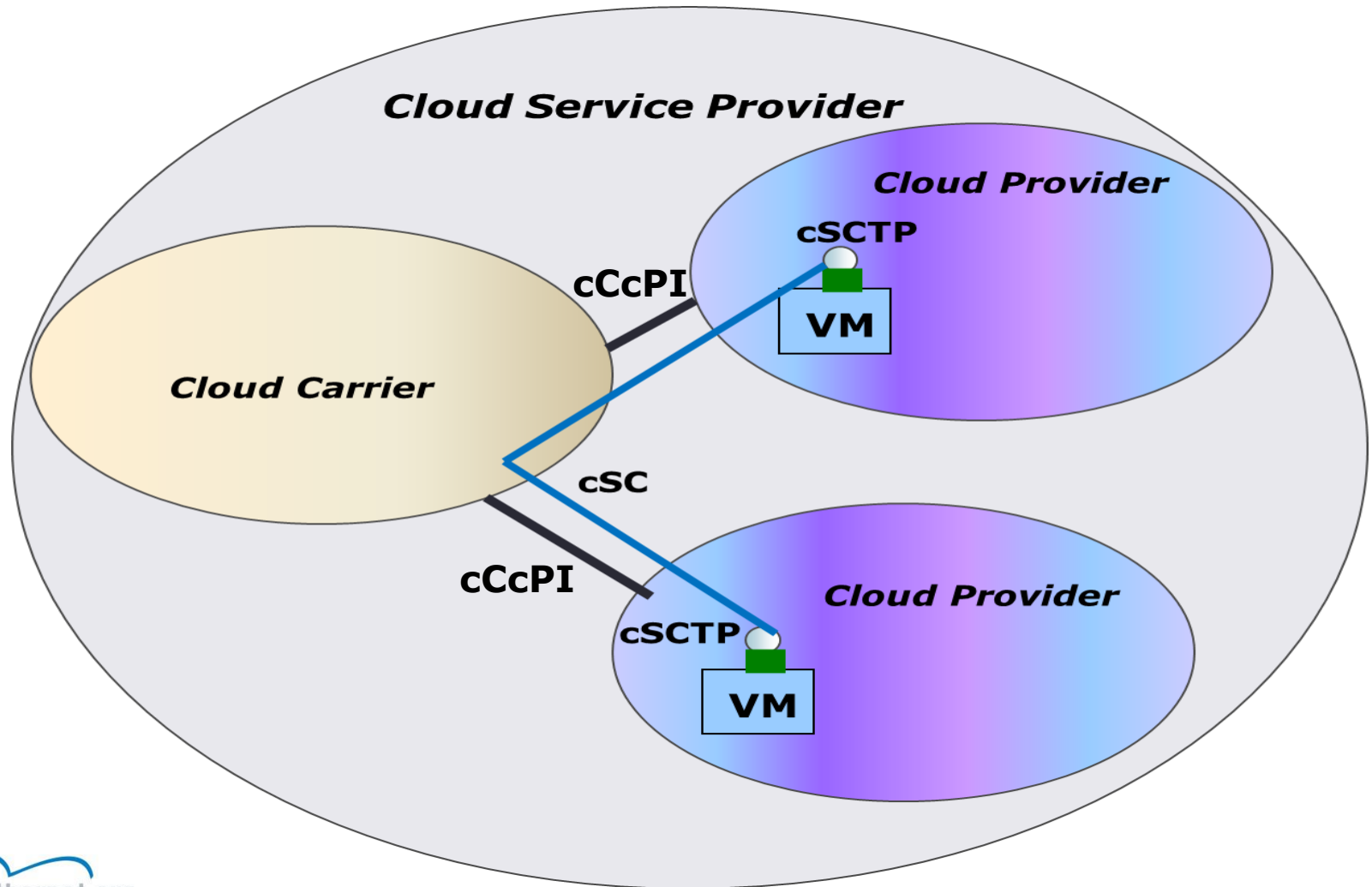



# Segments of cSC Crossing cC and cP

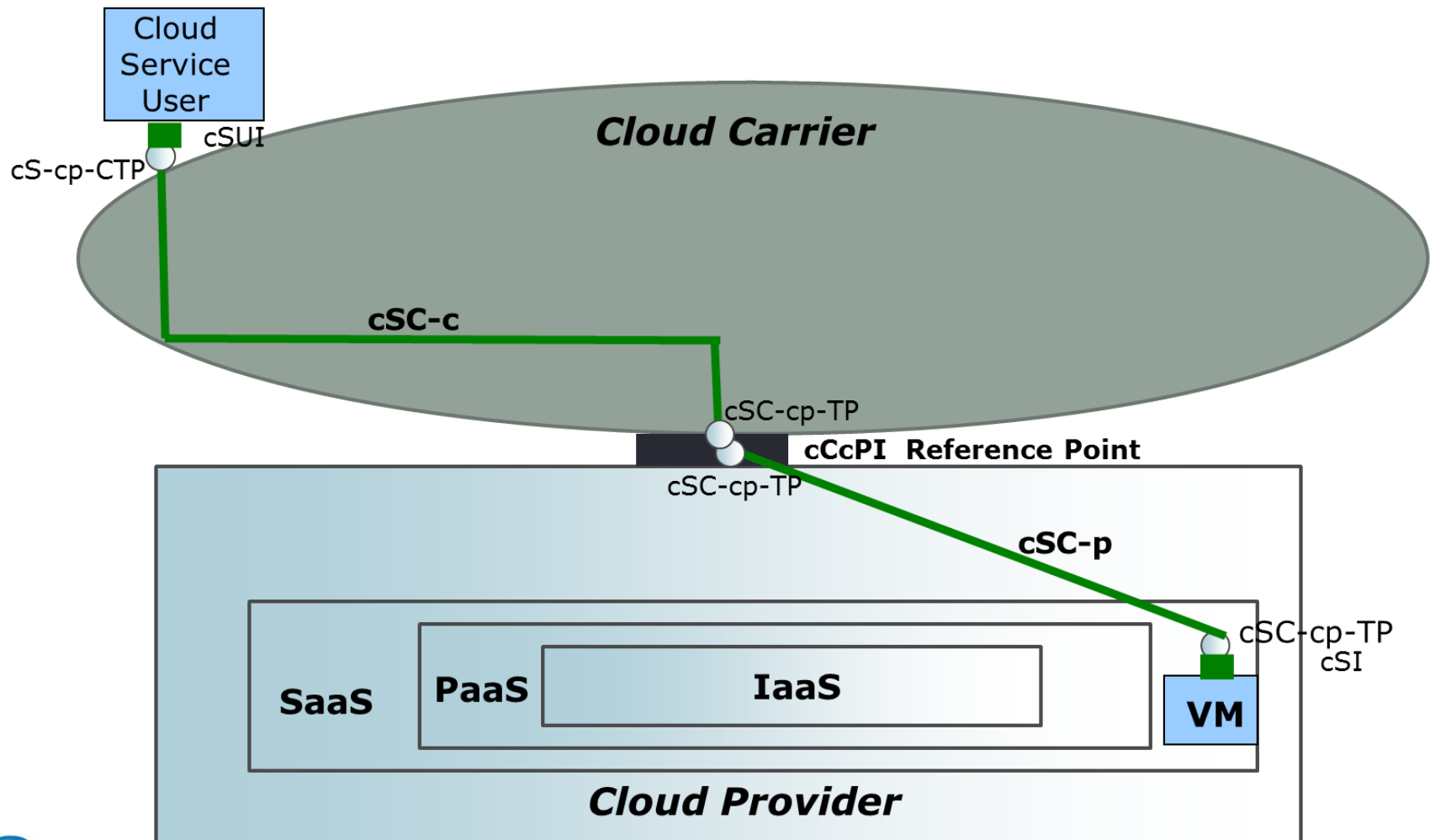

# Cloud Services by Two cSPs

**cSPcSPI: Cloud Service Provider Cloud Service Provider Interface**

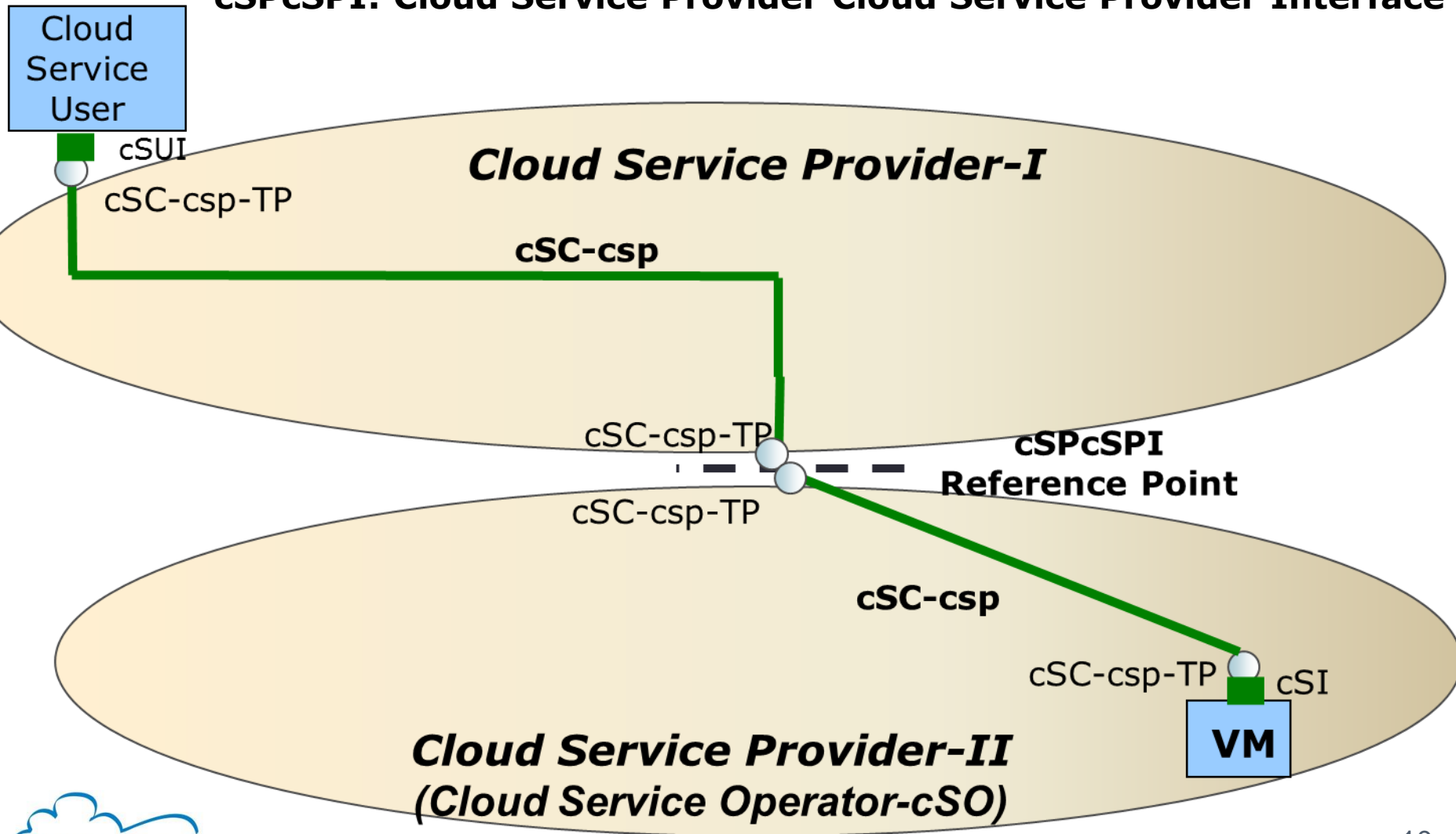

# Interfaces

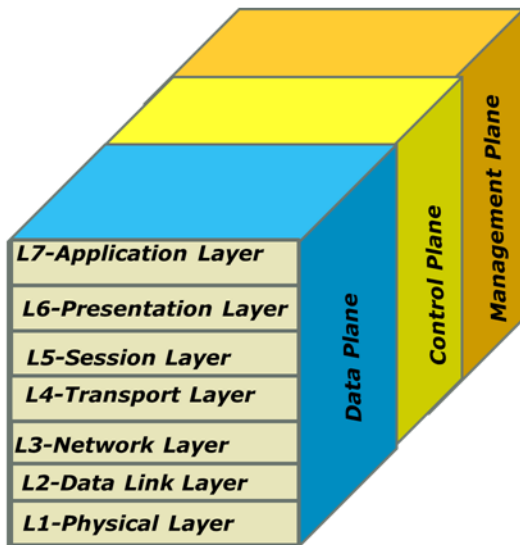

cSUI

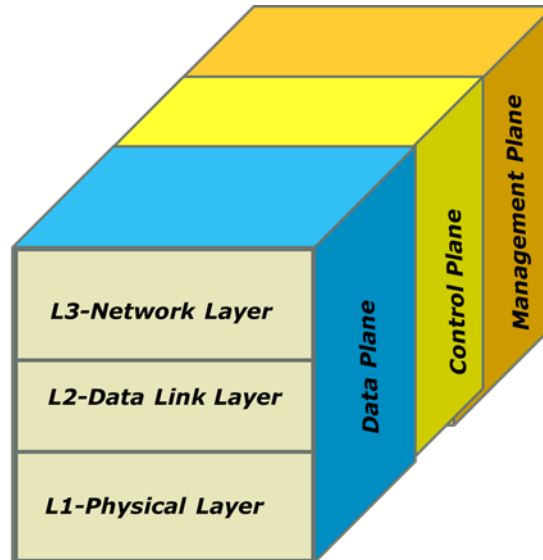

cSPcSPI  
Or  
cCcPI

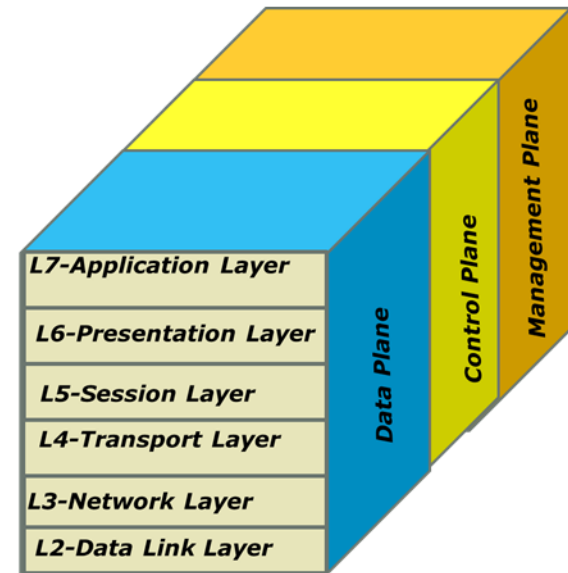

cSI

# cSI

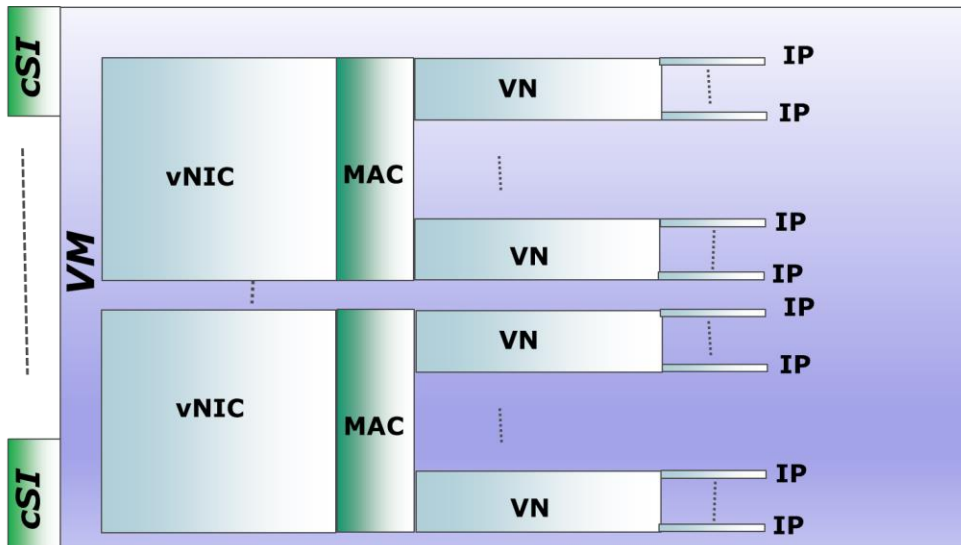
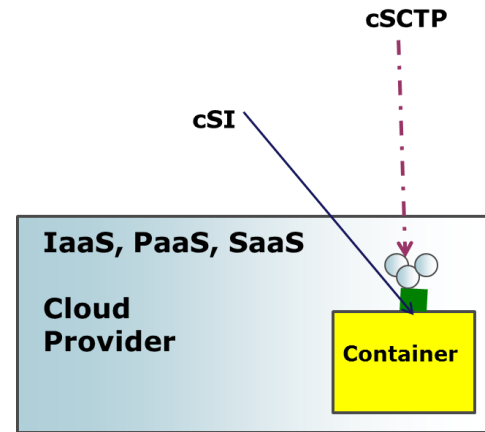
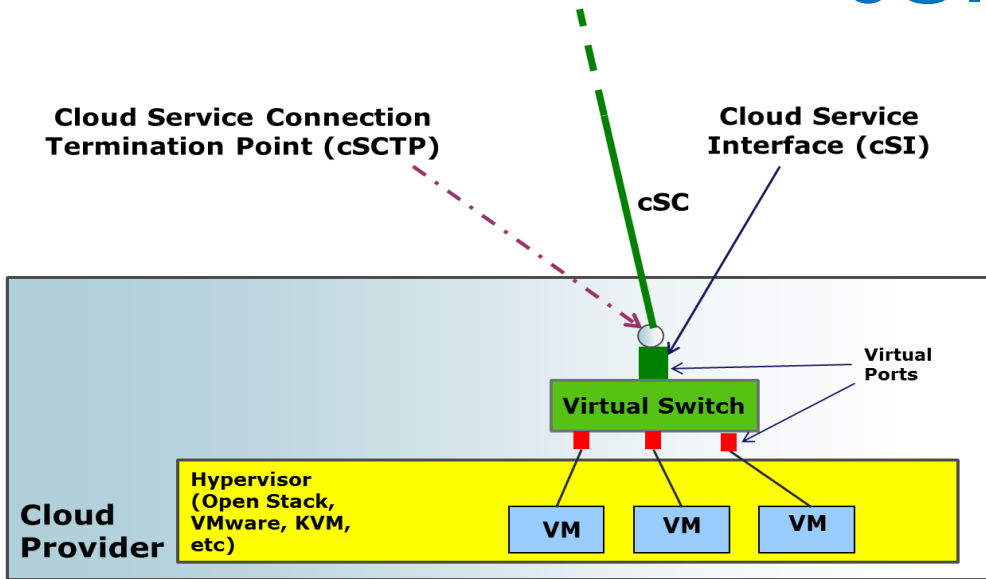

# cSUI Attributes

- ***cSUI Id, Tenant ID***
- ***NaaS Id***
- ***Physical Interface: Ethernet, DOCSIS, EPON, GPON, WDM, SONET/SDH, OTN***
- ***MTU***
- ***Connection Multiplexing***
- ***Protection***
- ***Maximum Number of Connection Termination Points***
- ***L2 Configuration Attributes [MEF10.3-MEF UNI], PPP, PPTP, ....***
- ***L2 SOAM Attributes [MEF30.1 and 30.2]***
- ***MPLS UNI Attributes [MPLS PVC User-to-Network Interface]***
- ***IPv4 address, IPv6 address***
- ***IP VPN***
- ***L4 attributes***
- ***L5 attributes***
- ***L6 attributes***
- ***L7 attributes***
- ***Interface Level Security***
- ***Service Level Security***
- ***Operational State***
- ***Administrative State***

# cSI Attributes

- ***cSI Id, VM ID***
- ***List of NaaS Ids***
- ***Interface Protection***
- ***VM Protection***
- ***MTU***
- ***Connection Multiplexing***
- ***Maximum Number of Connection Termination Points***
- ***VM Portability***
- ***L2 Configuration Attributes [MEF10.3-MEF UNI], PPP, PPTP, ....***
- ***L2 SOAM Attributes [MEF30.1 and 30.2]***
- ***MPLS UNI Attributes [MPLS PVC User-to-Network Interface]***
- ***IPv4 address, IPv6 address***
- ***IP VPN***
- ***L4 attributes***
- ***L5 attributes***
- ***L6 attributes***
- ***L7 attributes***
- ***Interface Level Security***
- ***Service Level Security***
- ***Operational State***
- ***Administrative State***

# Cloud Service Connection Termination Point (or End Point) (cSCTP)

## ***Attributes***

***Dynamic Attributes***

***Traffic Management***

***Fault Management***

***Performance Management***

***Protection***

***Security***

# Cloud Service Connection (cSC)

## ***Attributes***

***Dynamic Attributes***

***SLOs***

***Fault Management***

***Performance Management***

***Protection***

***Billing***

# Cloud Carrier-Provider Connection Termination Point (cSC-cp-TP)

## ***Attributes***

***Dynamic Attributes***

***Traffic Management***

***Fault Management***

***Performance Management***

***Protection***

***Security***

# Cloud Service Provider Connection (cSC- csp)

## ***Attributes***

***Dynamic Attributes***

***SLOs***

***Fault Management***

***Performance Management***

***Protection***

***Billing***



# Cloud Services

- ***NaaS (MEF Services, Load Balancing, ELB, Domain Registration Service, Managed DNS, Network Appliances, IPv4/v6 Capable Dual Stack, Elastic IP Services, Overlay Network Services,..)***
- ***IaaS (Storage Services, Databases, Disaster Recovery, Cloud Computing (Bare Metal Servers, High Performance Computing, Virtual Servers, ...))***
- ***SECaaS (Managed access, NaaS security, Traffic Cleaning, etc.)***
- ***PaaS (Managed application platform, scalable and high performing network, etc.)***
- ***SaaS (On-demand Software Installation, Licensing, CDN, Email)***
- ***CaaS (Virtual PBX, Voice and Video Conferencing, etc.)***

# Interconnectivity Services

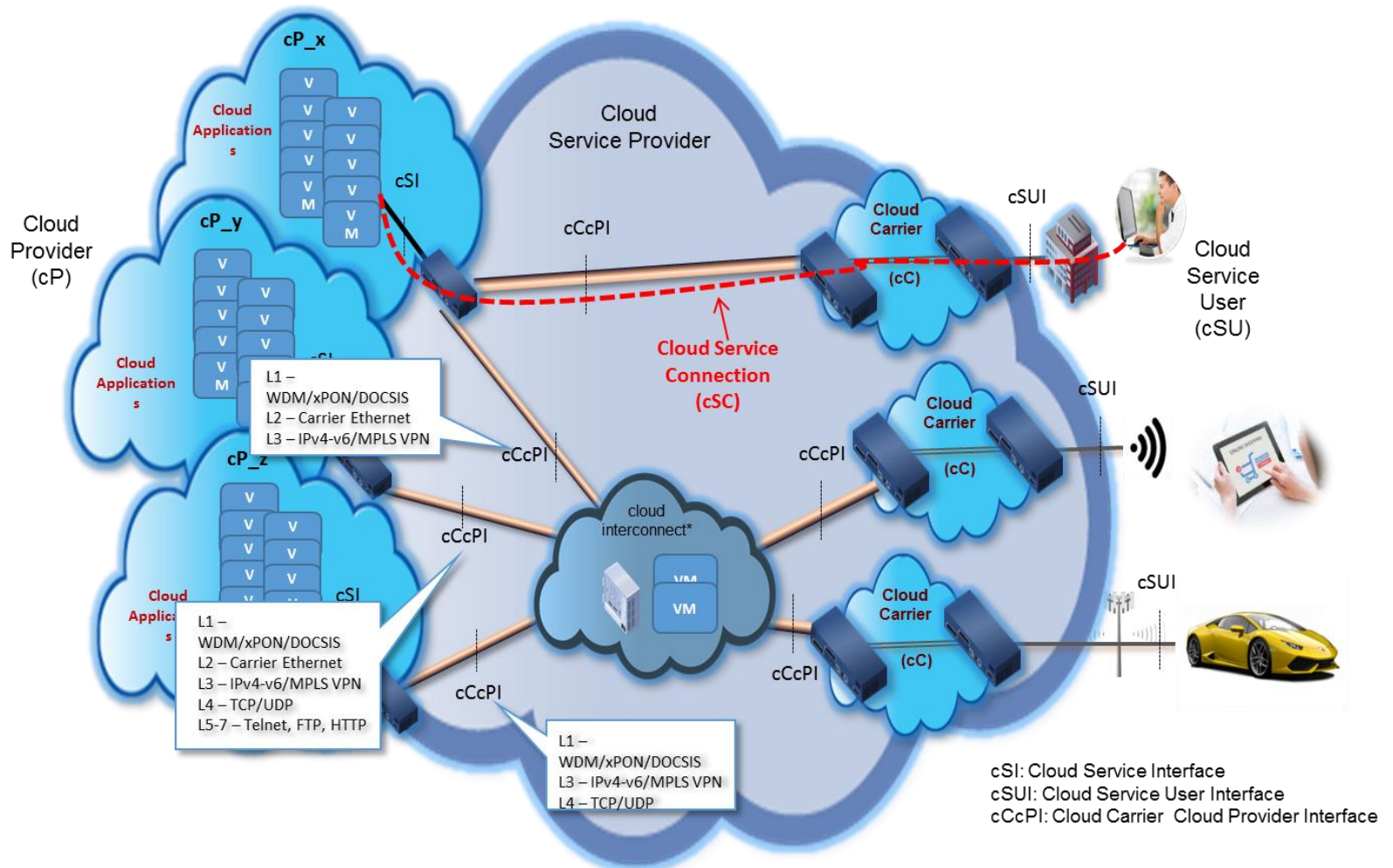

# NaaS Service Types

- ***EPL, EVPL, EP-LAN, EVP-LAN, EP-Tree, EVP-Tree, IP VPN, L2 VPN: On-demand with SLOs***
- ***On-Demand Load Balancing: Local, global, or high availability LB***
- ***Elastic Load Balancing***
- ***Domain Registration Service***
- ***Managed DNS***
- ***Network Appliances (Firewalls, Routers, ...)***
- ***IPv4 and IPv6 Capable Dual Stack***
- ***Outbound Public Bandwidth***
- ***Inbound Public Bandwidth***
- ***Private Network Bandwidth***
- ***Private and Public Port***
- ***Elastic IP Addresses***
- ***Overlay Network Services: PBB/PBT, L3VPN, VXLAN***
- ***Security***

# NaaS Common Attributes

<b>Cloud Services</b>	
<b>Network as a Service(NaaS)</b>	<b>Service Name</b>
	<b>Bandwidth</b>
	<b>Scheduled</b>
	<b>Shared</b>
	<b>Dedicated</b>
	<b>On-Demand</b>
	<b>Duration of Resource</b>
	<b>IPv4/IPv6 Address, VLAN and MAC</b>
	<b>Filtering</b>
	<b>NAT</b>
	<b>Firewall</b>
	<b>User Authentication</b>
	<b>Encryption</b>
	<b>Dynamic Scalability</b>
<b>Billing</b>	

# IaaS Common Attributes

<b>Cloud Services</b>	
<b>Infrastructure (i.e. IaaS)</b>	<b>Service Name</b>
	<b>CPU</b>
	<b>Memory</b>
	<b>Hard Disk Space</b>
	<b>Dedicated</b>
	<b>Shared</b>
	<b>Scheduled</b>
	<b>On-Demand</b>
	<b>Duration of Resource</b>
	<b>Operating Systems</b>
	<b>User Authentication</b>
	<b>Encryption</b>
	<b>Data Security</b>
	<b>Dynamic Scalability</b>
	<b>NaaS attributes</b>
	<b>Billing</b>

# PaaS Common Attributes

<b>Cloud Services</b>	
<b>Platform as a Service (PaaS)</b>	<b>Service Name</b>
	<b>CPU</b>
	<b>Memory</b>
	<b>Hard Disk Space</b>
	<b>Dedicated</b>
	<b>Shared</b>
	<b>Scheduled</b>
	<b>On-Demand</b>
	<b>Duration of Resource</b>
	<b>Operating Systems</b>
	<b>User Authentication</b>
	<b>Encryption</b>
	<b>Dynamic Scalability</b>
	<b>Data Security</b>
	<b>NaaS attributes</b>
<b>Billing</b>	

# SaaS, CaaS, and SECaaS Common Attributes

<b>Cloud Services</b>	
<b>Software as a Service (SaaS)</b>	<b>Service Name</b>
	<b>Licensing</b>
	<b>On-demand Software Installation</b>
	<b>NaaS Attributes</b>
<b>Communications as a Service (CaaS)</b>	<b>Service Name</b>
	<b>Number of users</b>
	<b>Licensed</b>
	<b>Unlicensed</b>
	<b>SLAs</b>
	<b>Service Type</b>
	<b>Data Security</b>
	<b>Authentication Realm</b>
	<b>NaaS attributes</b>
	<b>Billing</b>
<b>Security as a Service (SECaaS)</b>	<b>Security Service Type</b>
	<b>Security function</b>
	<b>Billing</b>

# OAM for Cloud Services

- **Service Availability-**
  - **Monthly Uptime of four 9s or five 9s**
  - **Unavailable-No external connectivity, Zero read/write I/O, etc.**
- **Provisioning-Rapid provisioning, resource changing, automated OS reload, remote reboot, etc.**
- **Performance Management-Periodic measurements, TCA, etc.**
- **Fault Management-Discovering and monitoring virtual resources, scheduled maintenance, upgrade events, etc.**
- **Billing-Fixed, Usage Based, etc.**
- **Testing-Verification of attributes of each interface, connections, cloud services**



# OCC vs ETSI NFV Architectures

## OCC Architecture

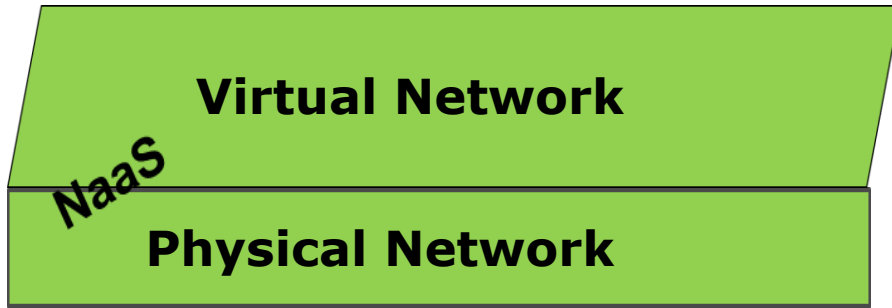

cCcPI  
Or  
cSUI  
Or  
cSPcSPI

## VNF Architecture

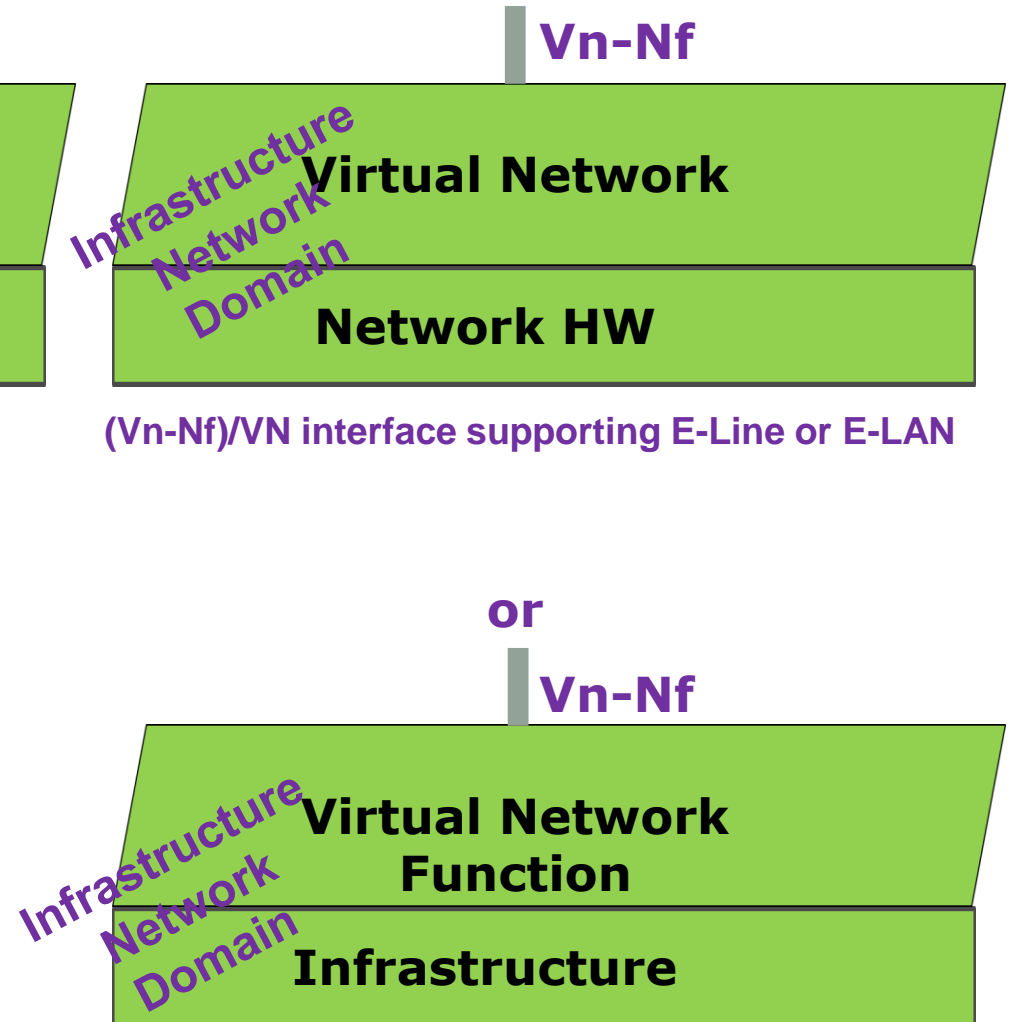

# ETSI NFV Bare Metal Server and VNF Interfaces

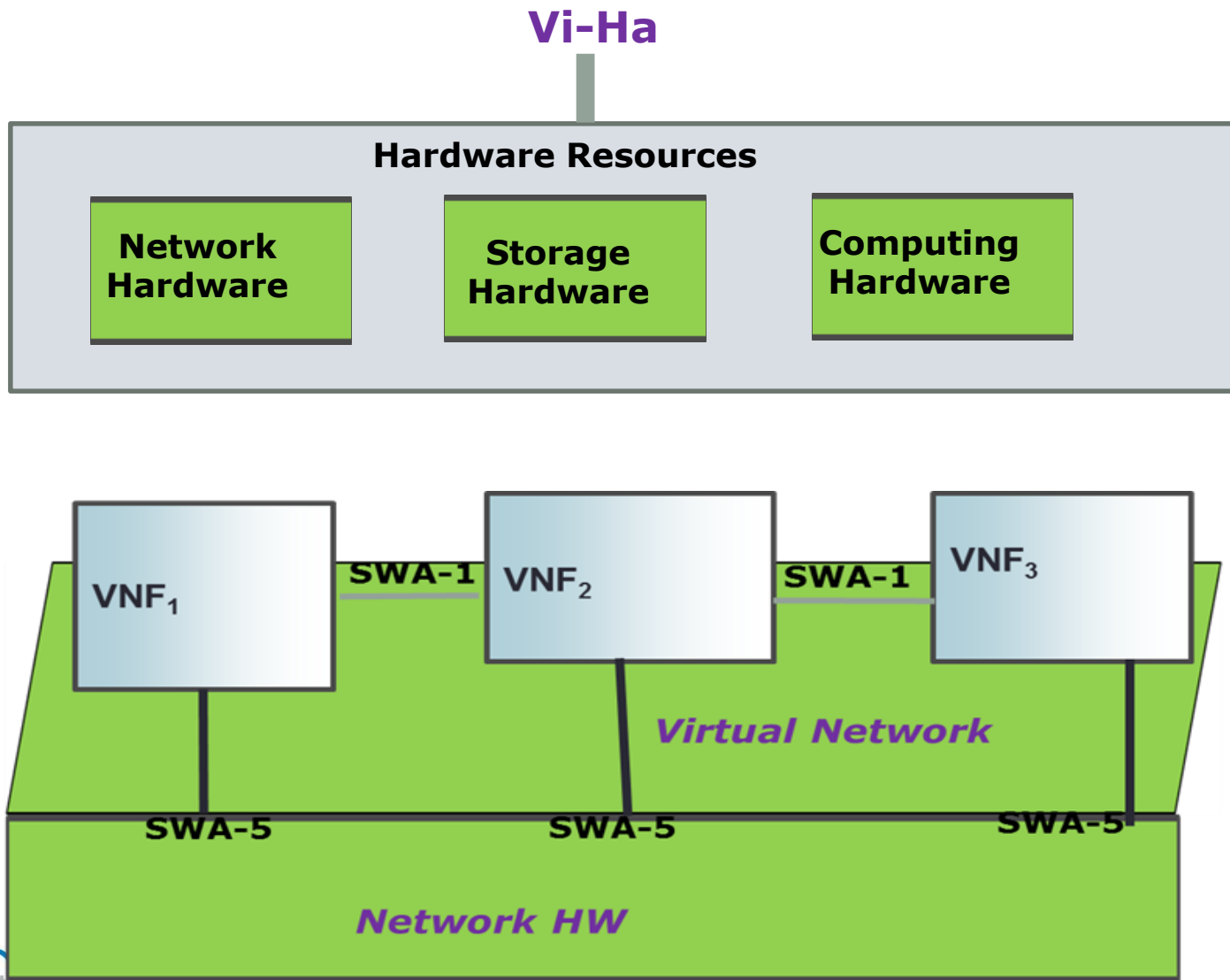

# VM Interfaces

## OCC Architecture

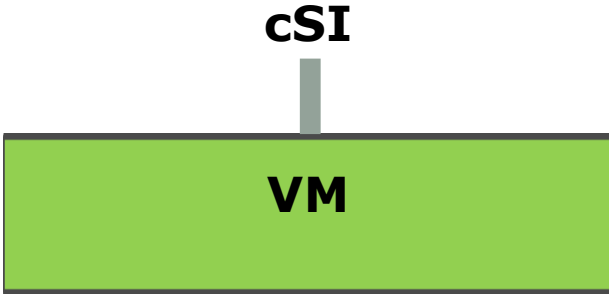

## VNF Architecture

(Vn-Nf)/VM  
Or  
Vn-Nf-VM

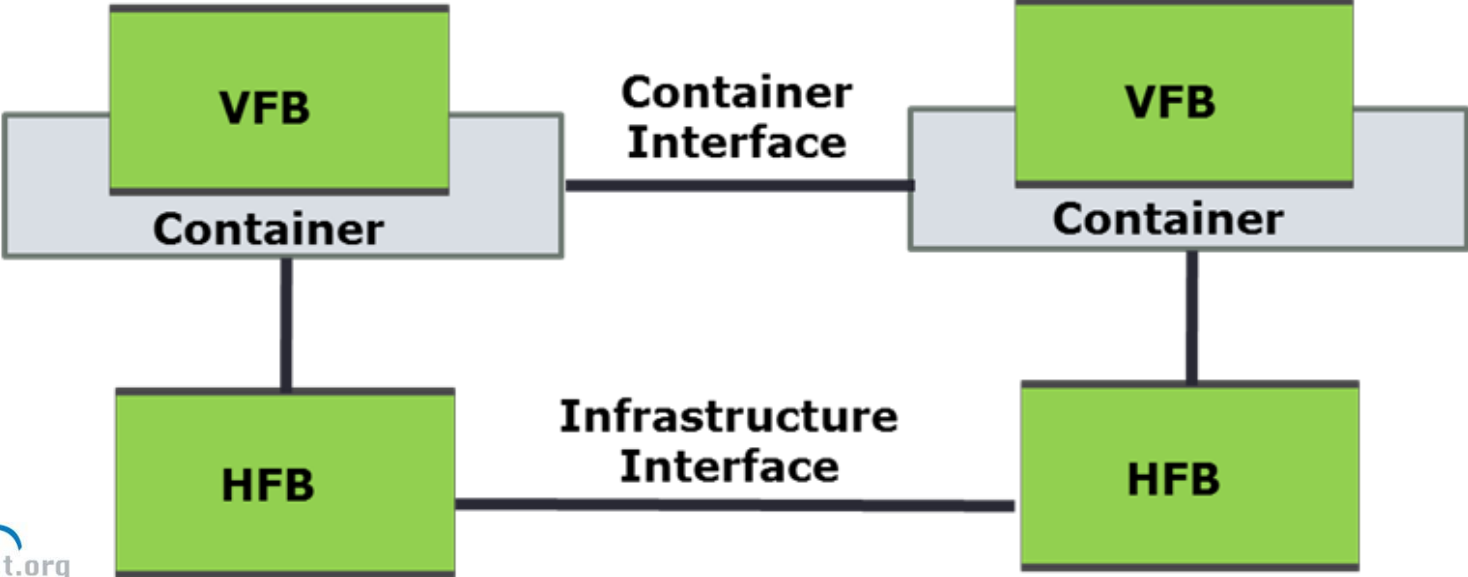
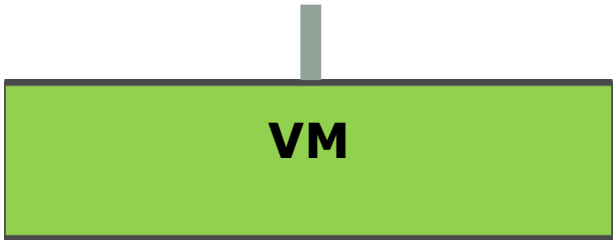

# Mapping of OCC and NFV Interfaces

<b>Architectural Construct</b>	<b>ETSI NFV Construct</b>	<b>OCC Construct</b>
<b>User Interface</b>	<b>(Vi-Ha)+(Vn-Nf)/VN</b>	<b>cSUI</b>
<b>VM Interface</b>	<b>(Vn-Nf)/VM</b>	<b>cSI</b>
<b>Container Interface</b>	<b>Container Interface</b>	<b>cSI</b>
<b>SWA-1</b>	<b>Software Architecture-1</b>	<b>cSI</b>
<b>Cloud Carrier-Cloud Provider Interface</b>		<b>cCcPI</b>
<b>Cloud Service Provider-Cloud Service Provider Interface</b>		<b>cSPcSPI</b>
<b>Connection between Users or between a User and VM or between VMs</b>	<b>VNF Forwarding Graph</b>	<b>cSC</b>
<b>Connection Termination Point</b>		<b>cSCTP</b>

# NaaS with VNF Interfaces

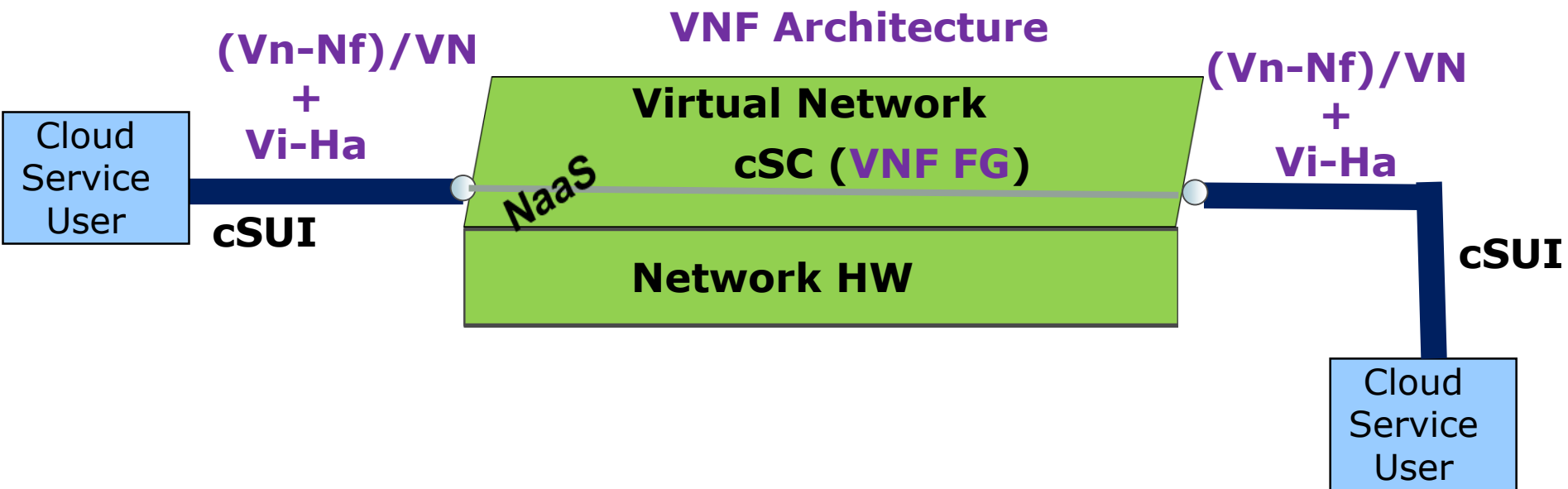

# NaaS with Bare Metal Server Interface

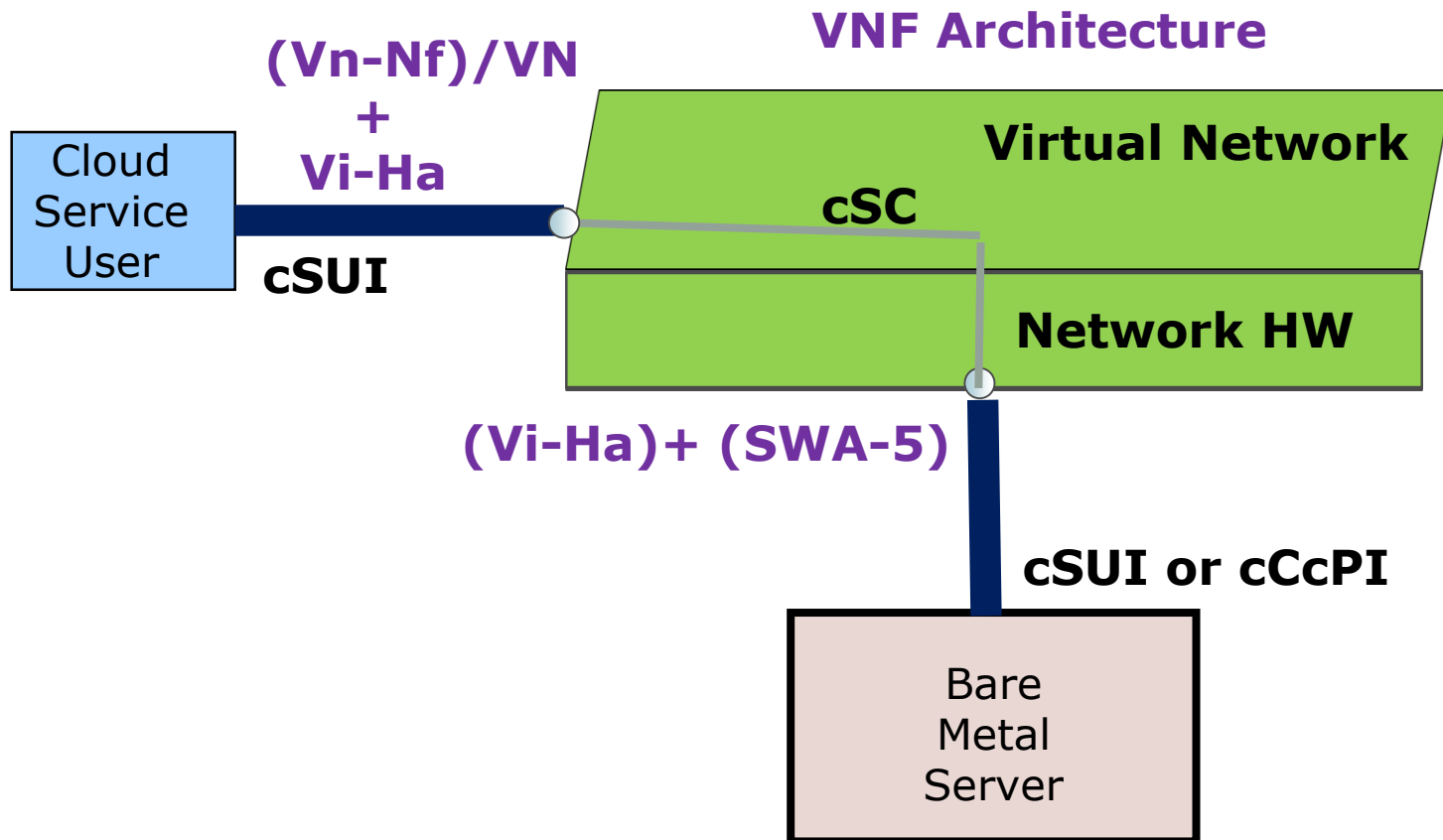

# VM Interface

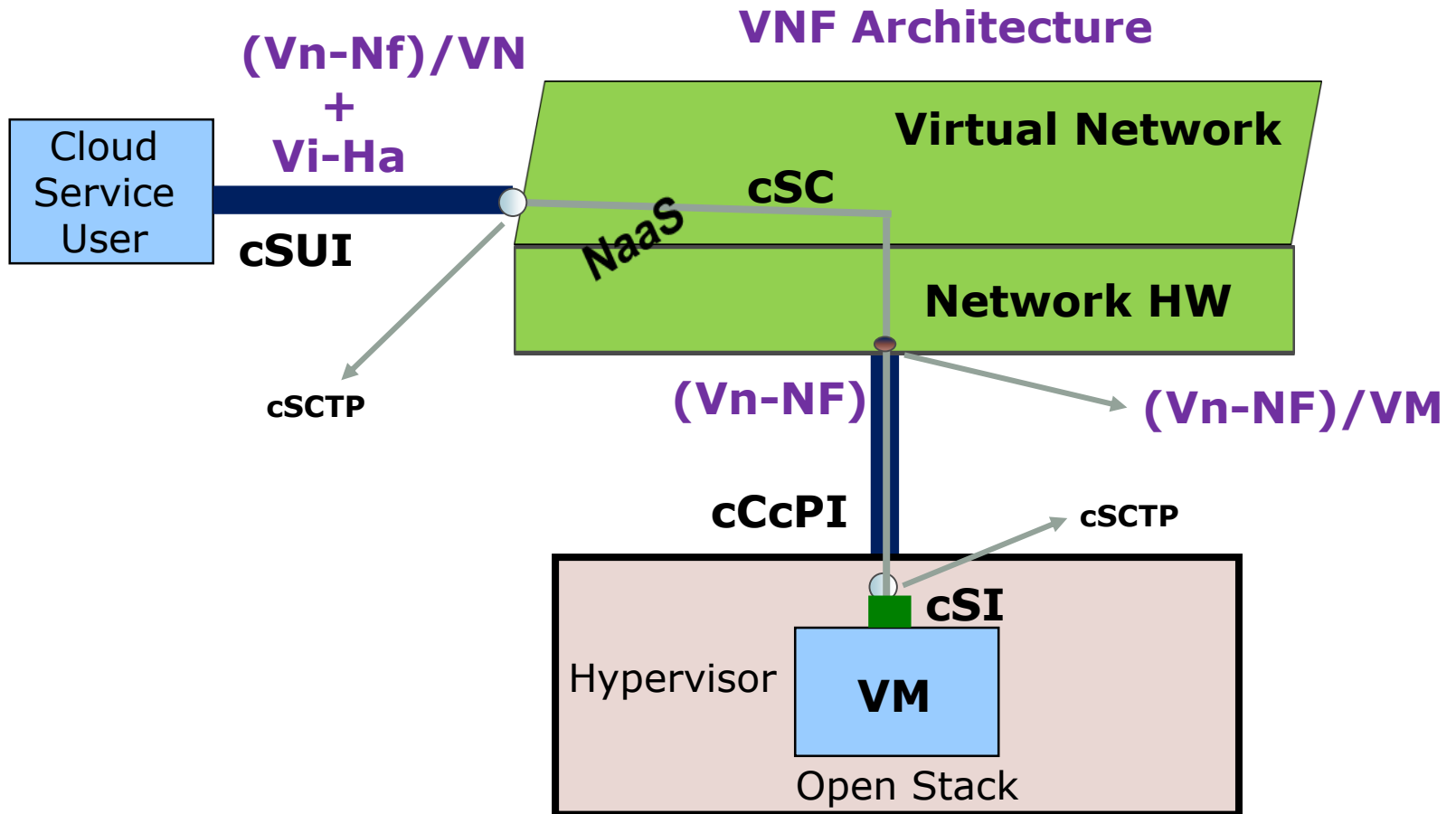

# Virtualized cSC between Two cSUs

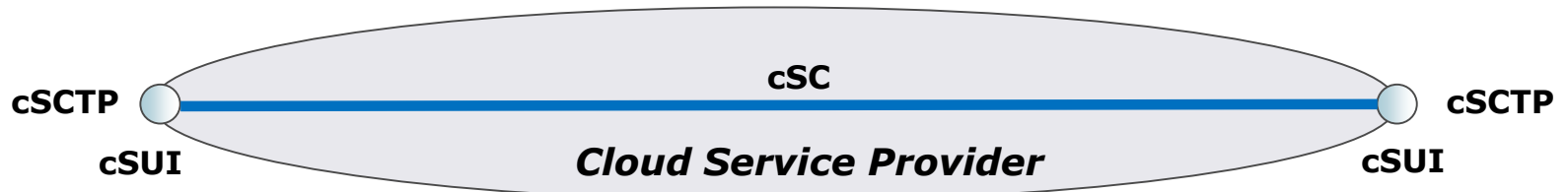

## Virtualized Implementation

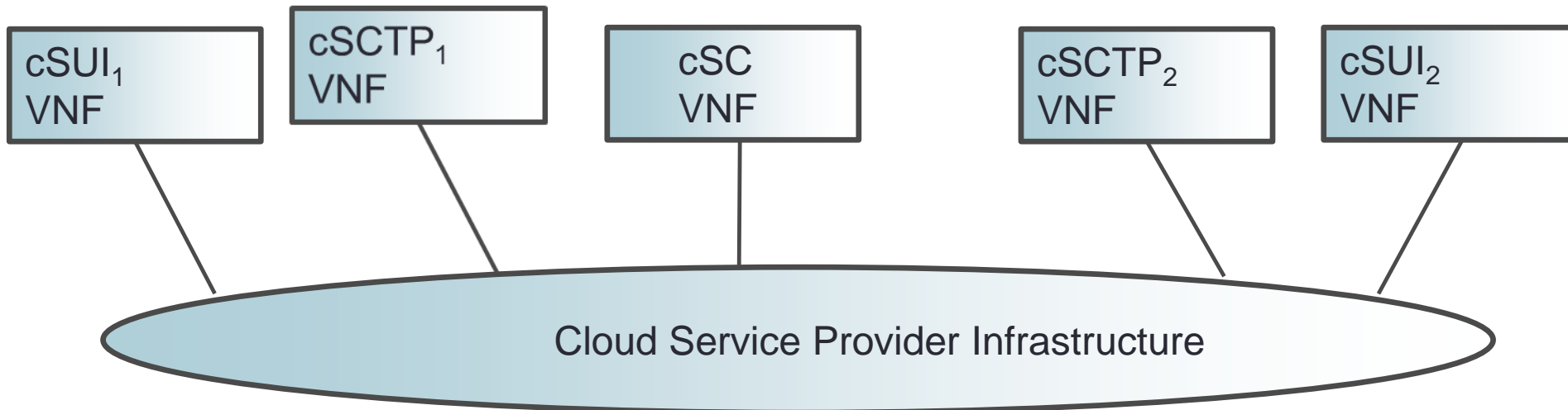



# Virtualized cSC between cSUI and cSI

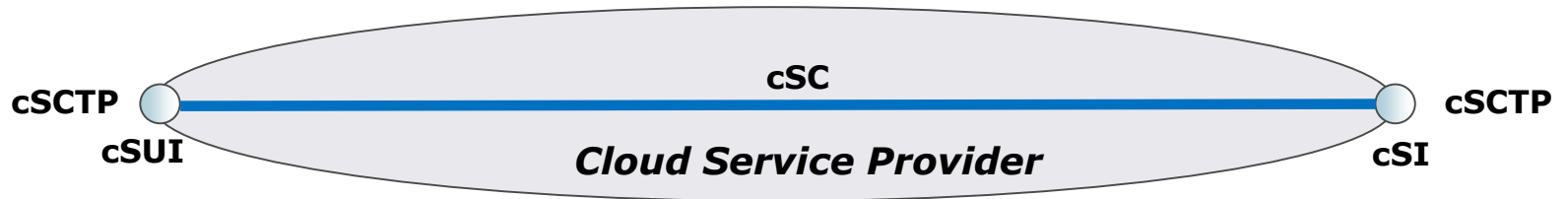

## Virtualized Implementation

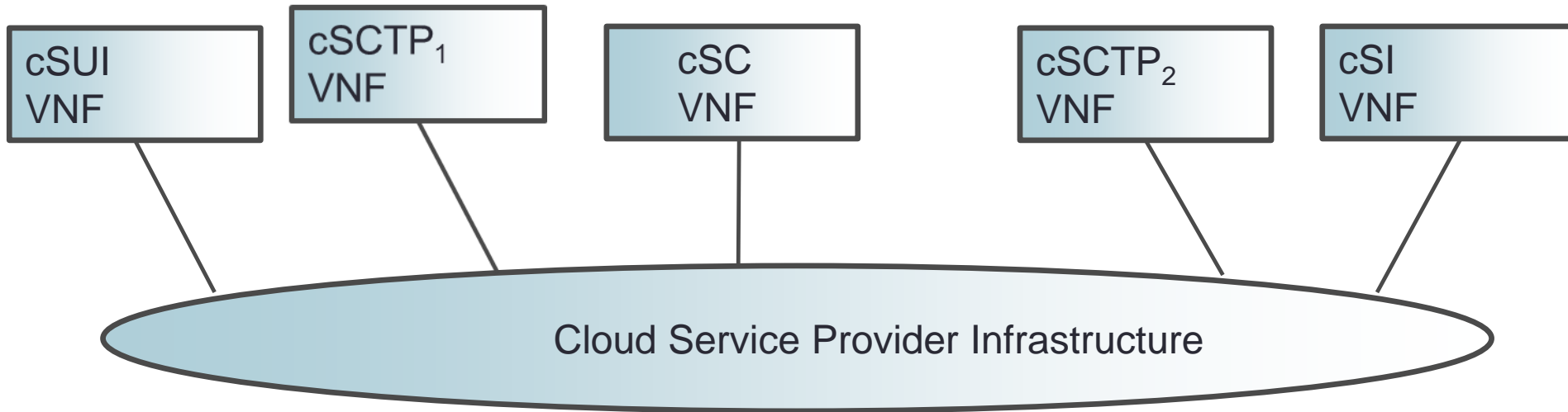

# Virtualized cSC Crossing Two cSPs

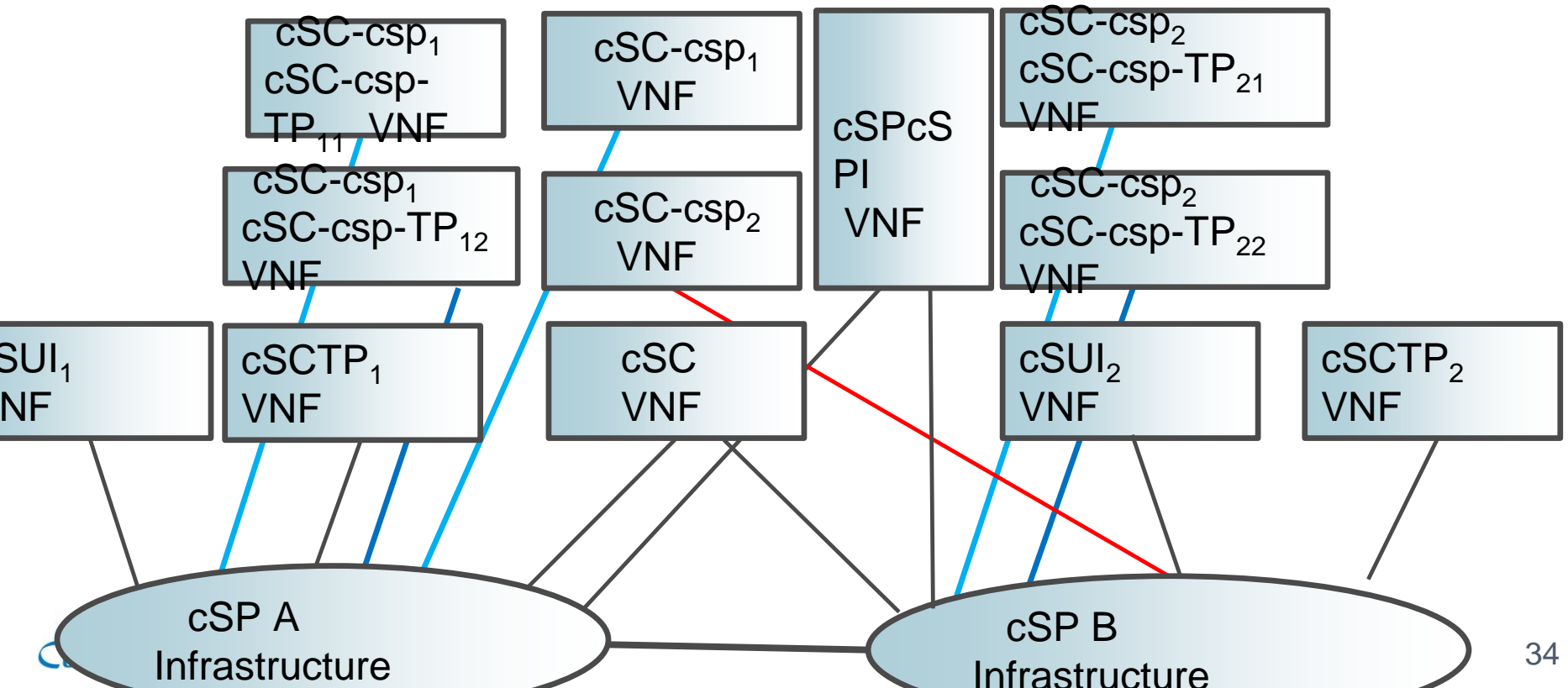
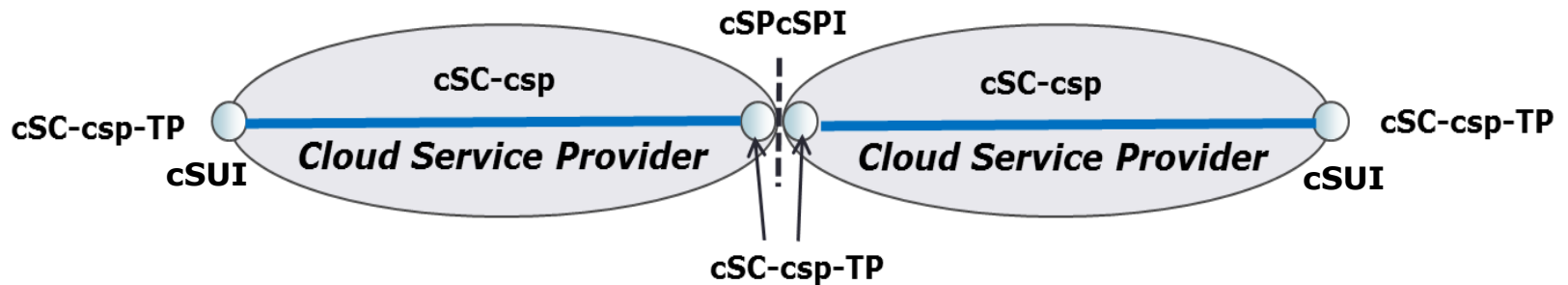

# SDN Architecture and Management

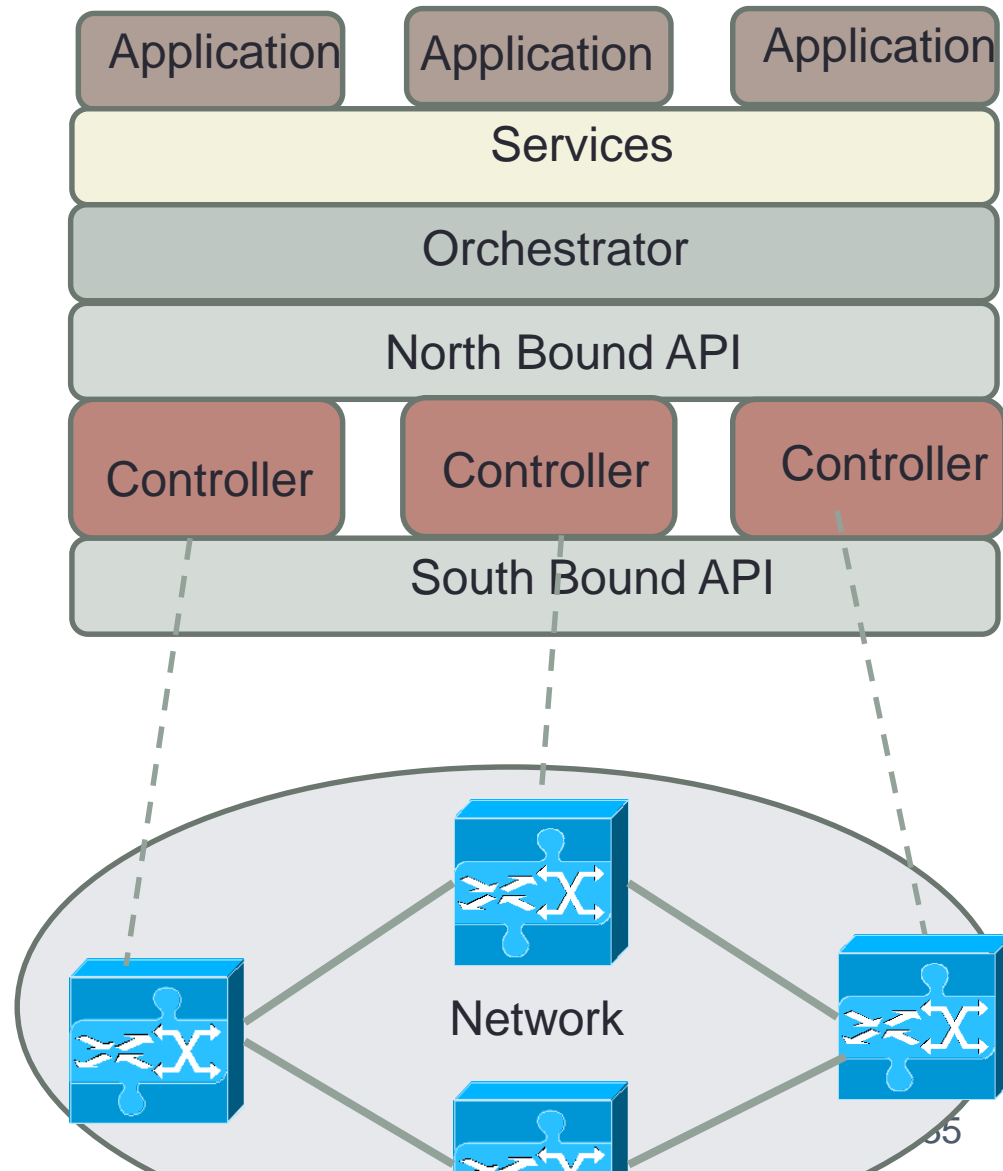
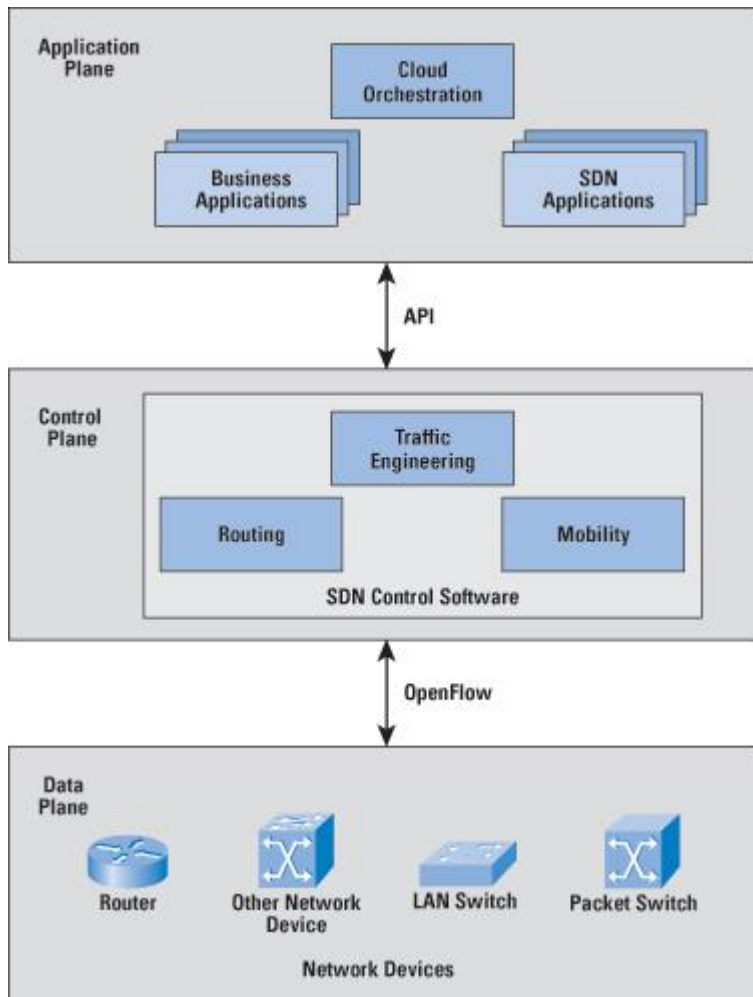

# Cloud Services Management

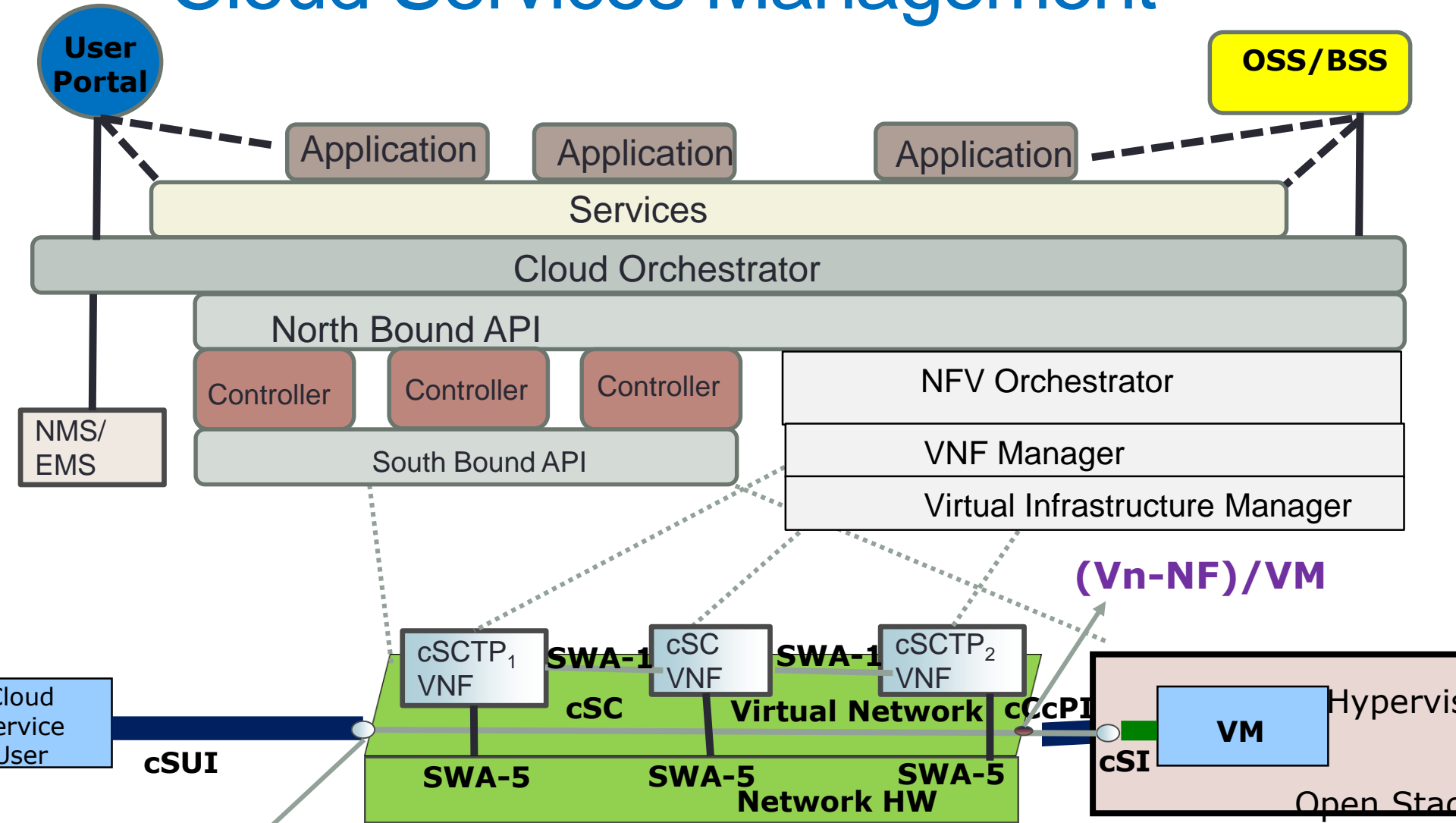

(Vn-Nf)/VN + Vi-Ha

# Cloud Services Management with Multiple Operators

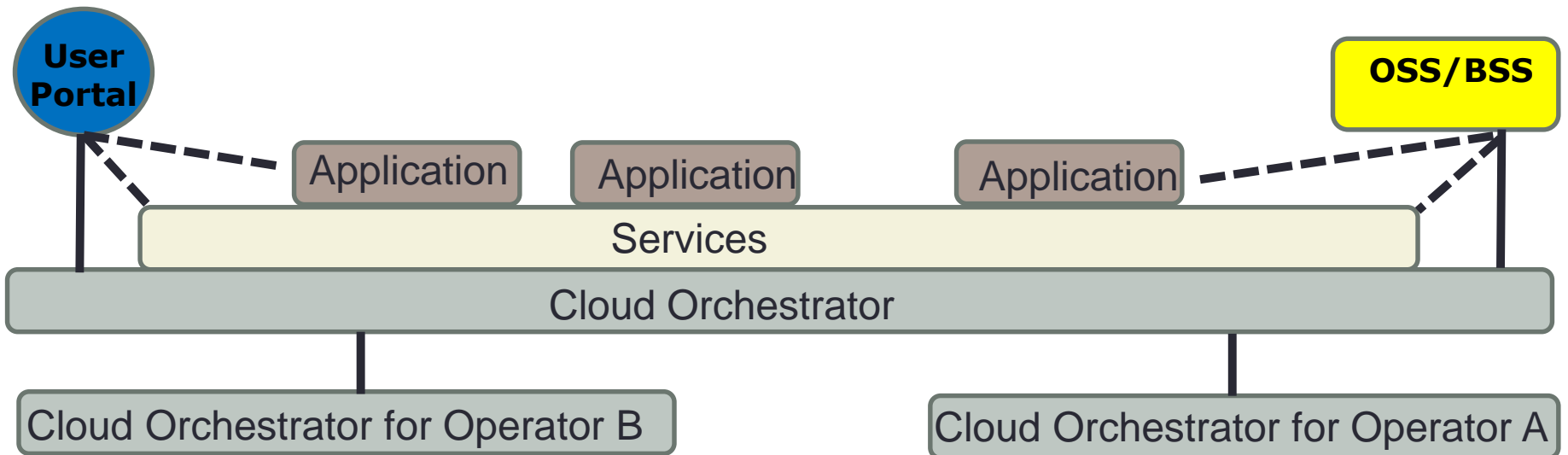

# LSO for Cloud Services

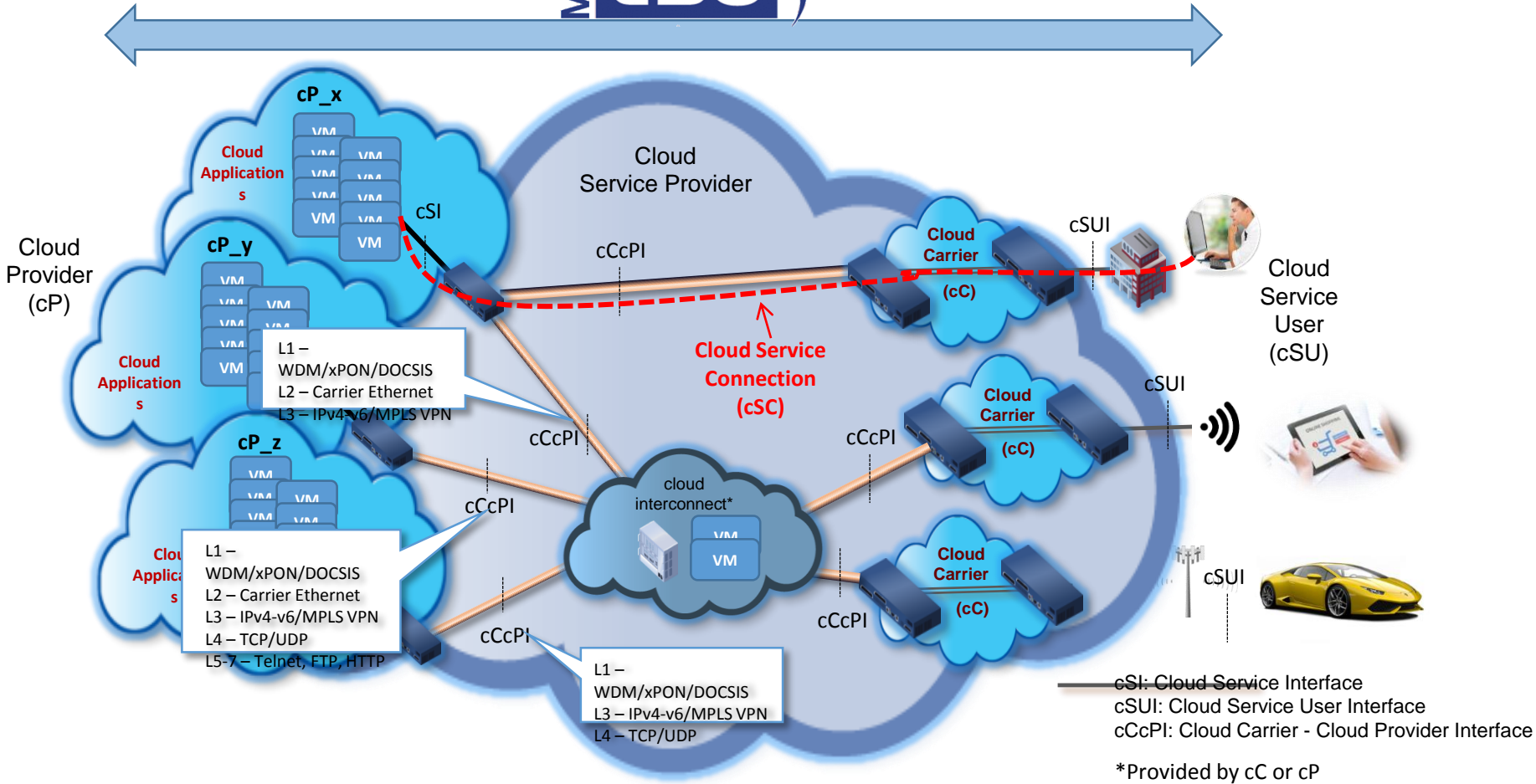

# OpenCloud Testbed

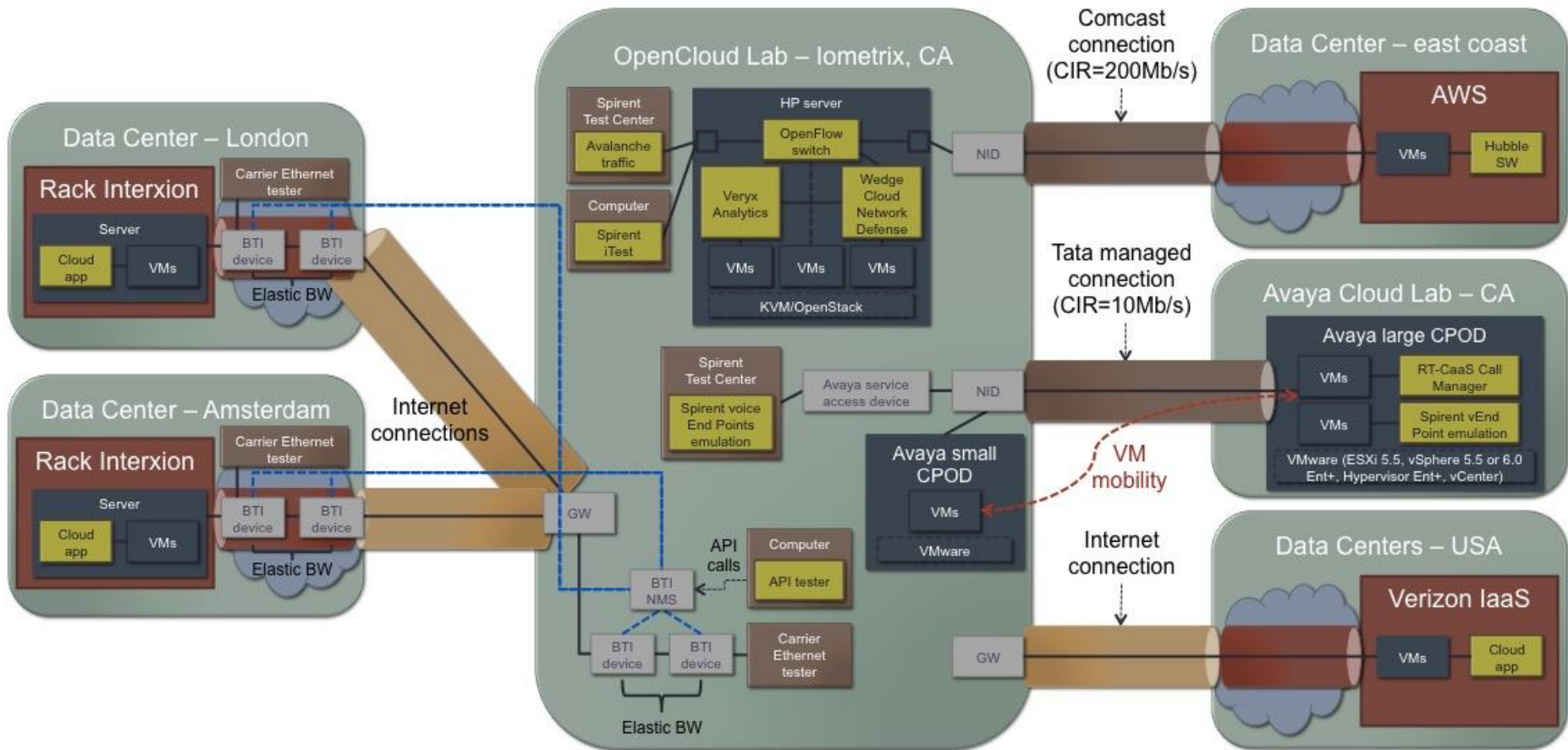

# What is Next?

- **Development of Implementation Agreements for Interfaces and Connections**
- **Development of Implementation Agreements for Services**
- **Development of Implementation Agreements for OAM and Service OAM**
- **Development of Testing and Certification Guidelines for Services**
- **Development of APIs and YANG Models**
- **Development of Life Cycle Service Orchestration for Cloud Services**
- **Collaborating with other SDOs for implementation, and API and YANG model development**



**Thank You!**

---

