

Network Working Group
Request for Comments: 4787
BCP: 127
Category: Best Current Practice

F. Audet, Ed.
Nortel Networks
C. Jennings
Cisco Systems
January 2007

Network Address Translation (NAT) Behavioral Requirements
for Unicast UDP

Status of This Memo

This document specifies an Internet Best Current Practices for the Internet Community, and requests discussion and suggestions for improvements. Distribution of this memo is unlimited.

Copyright Notice

Copyright (C) The IETF Trust (2007).

Abstract

This document defines basic terminology for describing different types of Network Address Translation (NAT) behavior when handling Unicast UDP and also defines a set of requirements that would allow many applications, such as multimedia communications or online gaming, to work consistently. Developing NATs that meet this set of requirements will greatly increase the likelihood that these applications will function properly.

Table of Contents

1. Applicability Statement	3
2. Introduction	3
3. Terminology	4
4. Network Address and Port Translation Behavior	5
4.1. Address and Port Mapping	5
4.2. Port Assignment	9
4.2.1. Port Assignment Behavior	9
4.2.2. Port Parity	11
4.2.3. Port Contiguity	11
4.3. Mapping Refresh	12
4.4. Conflicting Internal and External IP Address Spaces	13
5. Filtering Behavior	15
6. Hairpinning Behavior	16
7. Application Level Gateways	17
8. Deterministic Properties	18
9. ICMP Destination Unreachable Behavior	19
10. Fragmentation of Outgoing Packets	20
11. Receiving Fragmented Packets	20
12. Requirements	21
13. Security Considerations	24
14. IAB Considerations	25
15. Acknowledgments	26
16. References	26
16.1. Normative References	26
16.2. Informative References	26

1. Applicability Statement

The purpose of this specification is to define a set of requirements for NATs that would allow many applications, such as multimedia communications or online gaming, to work consistently. Developing NATs that meet this set of requirements will greatly increase the likelihood that these applications will function properly.

The requirements of this specification apply to Traditional NATs as described in [RFC2663].

This document is meant to cover NATs of any size, from small residential NATs to large Enterprise NATs. However, it should be understood that Enterprise NATs normally provide much more than just NAT capabilities; for example, they typically provide firewall functionalities. A comprehensive description of firewall behaviors and associated requirements is specifically out-of-scope for this specification. However, this specification does cover basic firewall aspects present in NATs (see Section 5).

Approaches using directly signaled control of middle boxes are out of scope.

UDP Relays (e.g., Traversal Using Relay NAT [TURN]) are out of scope.

Application aspects are out of scope, as the focus here is strictly on the NAT itself.

This document only covers aspects of NAT traversal related to Unicast UDP [RFC0768] over IP [RFC0791] and their dependencies on other protocols.

2. Introduction

Network Address Translators (NATs) are well known to cause very significant problems with applications that carry IP addresses in the payload (see [RFC3027]). Applications that suffer from this problem include Voice Over IP and Multimedia Over IP (e.g., SIP [RFC3261] and H.323 [ITU.H323]), as well as online gaming.

Many techniques are used to attempt to make realtime multimedia applications, online games, and other applications work across NATs. Application Level Gateways [RFC2663] are one such mechanism. STUN [RFC3489bis] describes a UNilateral Self-Address Fixing (UNSAF) mechanism [RFC3424]. Teredo [RFC4380] describes an UNSAF mechanism consisting of tunnelling IPv6 [RFC2460] over UDP/IPv4. UDP Relays have also been used to enable applications across NATs, but these are generally seen as a solution of last resort. Interactive

Connectivity Establishment [ICE] describes a methodology for using many of these techniques and avoiding a UDP relay, unless the type of NAT is such that it forces the use of such a UDP relay. This specification defines requirements for improving NATs. Meeting these requirements ensures that applications will not be forced to use UDP relay.

As pointed out in UNSAF [RFC3424], "From observations of deployed networks, it is clear that different NAT box implementations vary widely in terms of how they handle different traffic and addressing cases". This wide degree of variability is one factor in the overall brittleness introduced by NATs and makes it extremely difficult to predict how any given protocol will behave on a network traversing NAT. Discussions with many of the major NAT vendors have made it clear that they would prefer to deploy NATs that were deterministic and caused the least harm to applications while still meeting the requirements that caused their customers to deploy NATs in the first place. The problem NAT vendors face is that they are not sure how best to do that or how to document their NATs' behavior.

The goals of this document are to define a set of common terminology for describing the behavior of NATs and to produce a set of requirements on a specific set of behaviors for NATs.

This document forms a common set of requirements that are simple and useful for voice, video, and games, which can be implemented by NAT vendors. This document will simplify the analysis of protocols for deciding whether or not they work in this environment and will allow providers of services that have NAT traversal issues to make statements about where their applications will work and where they will not, as well as to specify their own NAT requirements.

3. Terminology

The key words "MUST", "MUST NOT", "REQUIRED", "SHALL", "SHALL NOT", "SHOULD", "SHOULD NOT", "RECOMMENDED", "MAY", and "OPTIONAL" in this document are to be interpreted as described in [RFC2119].

Readers are urged to refer to [RFC2663] for information on NAT taxonomy and terminology. Traditional NAT is the most common type of NAT device deployed. Readers may refer to [RFC3022] for detailed information on traditional NAT. Traditional NAT has two main varieties -- Basic NAT and Network Address/Port Translator (NAPT).

NAPT is by far the most commonly deployed NAT device. NAPT allows multiple internal hosts to share a single public IP address simultaneously. When an internal host opens an outgoing TCP or UDP session through a NAPT, the NAPT assigns the session a public IP

address and port number, so that subsequent response packets from the external endpoint can be received by the NAT, translated, and forwarded to the internal host. The effect is that the NAT establishes a NAT session to translate the (private IP address, private port number) tuple to a (public IP address, public port number) tuple, and vice versa, for the duration of the session. An issue of relevance to peer-to-peer applications is how the NAT behaves when an internal host initiates multiple simultaneous sessions from a single (private IP, private port) endpoint to multiple distinct endpoints on the external network. In this specification, the term "NAT" refers to both "Basic NAT" and "Network Address/Port Translator (NAPT)".

This document uses the term "session" as defined in RFC 2663: "TCP/UDP sessions are uniquely identified by the tuple of (source IP address, source TCP/UDP ports, target IP address, target TCP/UDP Port)".

This document uses the term "address and port mapping" as the translation between an external address and port and an internal address and port. Note that this is not the same as an "address binding" as defined in RFC 2663.

This document uses IANA terminology for port ranges, i.e., "Well Known Ports" is 0-1023, "Registered" is 1024-49151, and "Dynamic and/or Private" is 49152-65535, as defined in <http://www.iana.org/assignments/port-numbers>.

STUN [RFC3489] used the terms "Full Cone", "Restricted Cone", "Port Restricted Cone", and "Symmetric" to refer to different variations of NATs applicable to UDP only. Unfortunately, this terminology has been the source of much confusion, as it has proven inadequate at describing real-life NAT behavior. This specification therefore refers to specific individual NAT behaviors instead of using the Cone/Symmetric terminology.

4. Network Address and Port Translation Behavior

This section describes the various NAT behaviors applicable to NATs.

4.1. Address and Port Mapping

When an internal endpoint opens an outgoing session through a NAT, the NAT assigns the session an external IP address and port number so that subsequent response packets from the external endpoint can be received by the NAT, translated, and forwarded to the internal endpoint. This is a mapping between an internal IP address and port IP:port and external IP:port tuple. It establishes the translation

that will be performed by the NAT for the duration of the session. For many applications, it is important to distinguish the behavior of the NAT when there are multiple simultaneous sessions established to different external endpoints.

The key behavior to describe is the criteria for reuse of a mapping for new sessions to external endpoints, after establishing a first mapping between an internal X:x address and port and an external Y1:y1 address tuple. Let's assume that the internal IP address and port X:x are mapped to X1':x1' for this first session. The endpoint then sends from X:x to an external address Y2:y2 and gets a mapping of X2':x2' on the NAT. The relationship between X1':x1' and X2':x2' for various combinations of the relationship between Y1:y1 and Y2:y2 is critical for describing the NAT behavior. This arrangement is illustrated in the following diagram:

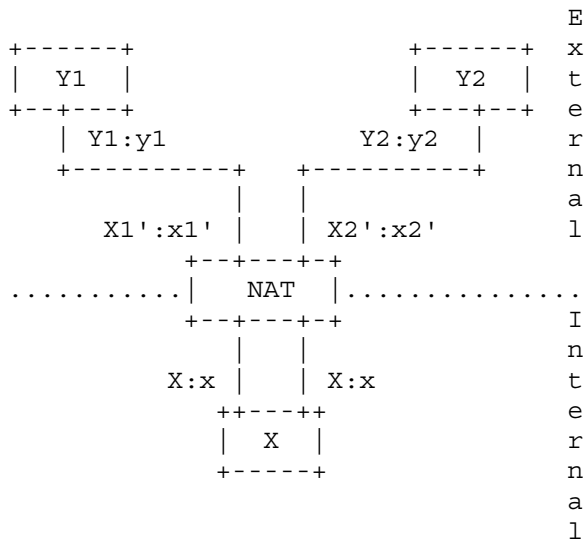

Address and Port Mapping

The following address and port mapping behavior are defined:

Endpoint-Independent Mapping:

The NAT reuses the port mapping for subsequent packets sent from the same internal IP address and port (X:x) to any external IP address and port. Specifically, X1':x1' equals X2':x2' for all values of Y2:y2.

Address-Dependent Mapping:

The NAT reuses the port mapping for subsequent packets sent from the same internal IP address and port (X:x) to the same external IP address, regardless of the external port. Specifically, X1':x1' equals X2':x2' if and only if, Y2 equals Y1.

Address and Port-Dependent Mapping:

The NAT reuses the port mapping for subsequent packets sent from the same internal IP address and port (X:x) to the same external IP address and port while the mapping is still active. Specifically, X1':x1' equals X2':x2' if and only if, Y2:y2 equals Y1:y1.

It is important to note that these three possible choices make no difference to the security properties of the NAT. The security properties are fully determined by which packets the NAT allows in and which it does not. This is determined by the filtering behavior in the filtering portions of the NAT.

REQ-1: A NAT MUST have an "Endpoint-Independent Mapping" behavior.

Justification: In order for UNSAF methods to work, REQ-1 needs to be met. Failure to meet REQ-1 will force the use of a UDP relay, which is very often impractical.

Some NATs are capable of assigning IP addresses from a pool of IP addresses on the external side of the NAT, as opposed to just a single IP address. This is especially common with larger NATs. Some NATs use the external IP address mapping in an arbitrary fashion (i.e., randomly): one internal IP address could have multiple external IP address mappings active at the same time for different sessions. These NATs have an "IP address pooling" behavior of "Arbitrary". Some large Enterprise NATs use an IP address pooling behavior of "Arbitrary" as a means of hiding the IP address assigned to specific endpoints by making their assignment less predictable. Other NATs use the same external IP address mapping for all sessions associated with the same internal IP address. These NATs have an "IP address pooling" behavior of "Paired". NATs that use an "IP address pooling" behavior of "Arbitrary" can cause issues for applications that use multiple ports from the same endpoint, but that do not negotiate IP addresses individually (e.g., some applications using RTP and RTCP).

REQ-2: It is RECOMMENDED that a NAT have an "IP address pooling" behavior of "Paired". Note that this requirement is not applicable to NATs that do not support IP address pooling.

Justification: This will allow applications that use multiple ports originating from the same internal IP address to also have the same external IP address. This is to avoid breaking peer-to-peer applications that are not capable of negotiating the IP address for RTP and the IP address for RTCP separately. As such it is envisioned that this requirement will become less important as applications become NAT-friendlier with time. The main reason why this requirement is here is that in a peer-to-peer application, you are subject to the other peer's mistake. In particular, in the context of SIP, if my application supports the extensions defined in [RFC3605] for indicating RTP and RTCP addresses and ports separately, but the other peer does not, there may still be breakage in the form of the stream losing RTCP packets. This requirement will avoid the loss of RTP in this context, although the loss of RTCP may be inevitable in this particular example. It is also worth noting that RFC 3605 is unfortunately not a mandatory part of SIP [RFC3261]. Therefore, this requirement will address a particularly nasty problem that will prevail for a significant period of time.

4.2. Port Assignment

4.2.1. Port Assignment Behavior

This section uses the following diagram for reference.

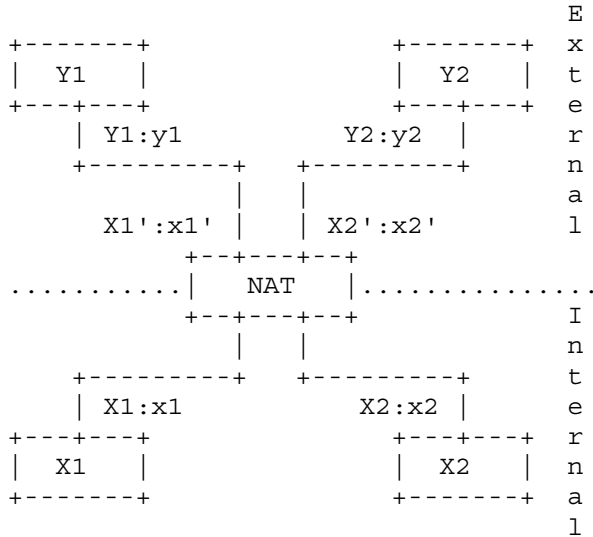

Port Assignment

Some NATs attempt to preserve the port number used internally when assigning a mapping to an external IP address and port (e.g., x1=x1', x2=x2'). This port assignment behavior is referred to as "port preservation". In case of port collision, these NATs attempt a variety of techniques for coping. For example, some NATs will overridden the previous mapping to preserve the same port. Other NATs will assign a different IP address from a pool of external IP addresses; this is only possible as long as the NAT has enough external IP addresses; if the port is already in use on all available external IP addresses, then these NATs will pick a different port (i.e., they don't do port preservation anymore).

Some NATs use "Port overloading", i.e., they always use port preservation even in the case of collision (i.e., X1'=X2' and x1=x2=x1'=x2'). Most applications will fail if the NAT uses "Port overloading".

A NAT that does not attempt to make the external port numbers match the internal port numbers in any case is referred to as "no port preservation".

When NATs do allocate a new source port, there is the issue of which IANA-defined range of port to choose. The ranges are "well-known" from 0 to 1023, "registered" from 1024 to 49151, and "dynamic/private" from 49152 through 65535. For most protocols, these are destination ports and not source ports, so mapping a source port to a source port that is already registered is unlikely to have any bad effects. Some NATs may choose to use only the ports in the dynamic range; the only downside of this practice is that it limits the number of ports available. Other NAT devices may use everything but the well-known range and may prefer to use the dynamic range first, or possibly avoid the actual registered ports in the registered range. Other NATs preserve the port range if it is in the well-known range. [RFC0768] specifies that the source port is set to zero if no reply packets are expected. In this case, it does not matter what the NAT maps it to, as the source port will not be used. However, many common OS APIs do not allow a user to send from port zero, applications do not use port zero, and the behavior of various existing NATs with regards to a packet with a source of port zero is unknown. This document does not specify any normative behavior for a NAT when handling a packet with a source port of zero which means that applications cannot count on any sort of deterministic behavior for these packets.

REQ-3: A NAT MUST NOT have a "Port assignment" behavior of "Port overloading".

- a) If the host's source port was in the range 0-1023, it is RECOMMENDED the NAT's source port be in the same range. If the host's source port was in the range 1024-65535, it is RECOMMENDED that the NAT's source port be in that range.

Justification: This requirement must be met in order to enable two applications on the internal side of the NAT both to use the same port to try to communicate with the same destination. NATs that implement port preservation have to deal with conflicts on ports, and the multiple code paths this introduces often result in nondeterministic behavior. However, it should be understood that when a port is randomly assigned, it may just randomly happen to be assigned the same port. Applications must, therefore, be able to deal with both port preservation and no port preservation.

- a) Certain applications expect the source UDP port to be in the well-known range. See the discussion of Network File System port expectations in [RFC2623] for an example.

4.2.2. Port Parity

Some NATs preserve the parity of the UDP port, i.e., an even port will be mapped to an even port, and an odd port will be mapped to an odd port. This behavior respects the [RFC3550] rule that RTP use even ports, and RTCP use odd ports. RFC 3550 allows any port numbers to be used for RTP and RTCP if the two numbers are specified separately; for example, using [RFC3605]. However, some implementations do not include RFC 3605, and do not recognize when the peer has specified the RTCP port separately using RFC 3605. If such an implementation receives an odd RTP port number from the peer (perhaps after having been translated by a NAT), and then follows the RFC 3550 rule to change the RTP port to the next lower even number, this would obviously result in the loss of RTP. NAT-friendly application aspects are outside the scope of this document. It is expected that this issue will fade away with time, as implementations improve. Preserving the port parity allows for supporting communication with peers that do not support explicit specification of both RTP and RTCP port numbers.

REQ-4: It is RECOMMENDED that a NAT have a "Port parity preservation" behavior of "Yes".

Justification: This is to avoid breaking peer-to-peer applications that do not explicitly and separately specify RTP and RTCP port numbers and that follow the RFC 3550 rule to decrement an odd RTP port to make it even. The same considerations apply, as per the IP address pooling requirement.

4.2.3. Port Contiguity

Some NATs attempt to preserve the port contiguity rule of $RTCP=RTP+1$. These NATs do things like sequential assignment or port reservation. Sequential port assignment assumes that the application will open a mapping for RTP first and then open a mapping for RTCP. It is not practical to enforce this requirement on all applications. Furthermore, there is a problem with glare if many applications (or endpoints) are trying to open mappings simultaneously. Port preservation is also problematic since it is wasteful, especially considering that a NAT cannot reliably distinguish between RTP over UDP and other UDP packets where there is no contiguity rule. For those reasons, it would be too complex to attempt to preserve the contiguity rule by suggesting specific NAT behavior, and it would certainly break the deterministic behavior rule.

In order to support both RTP and RTCP, it will therefore be necessary that applications follow rules to negotiate RTP and RTCP separately, and account for the very real possibility that the $RTCP=RTP+1$ rule

will be broken. As this is an application requirement, it is outside the scope of this document.

4.3. Mapping Refresh

NAT mapping timeout implementations vary, but include the timer's value and the way the mapping timer is refreshed to keep the mapping alive.

The mapping timer is defined as the time a mapping will stay active without packets traversing the NAT. There is great variation in the values used by different NATs.

REQ-5: A NAT UDP mapping timer MUST NOT expire in less than two minutes, unless REQ-5a applies.

- a) For specific destination ports in the well-known port range (ports 0-1023), a NAT MAY have shorter UDP mapping timers that are specific to the IANA-registered application running over that specific destination port.
- b) The value of the NAT UDP mapping timer MAY be configurable.
- c) A default value of five minutes or more for the NAT UDP mapping timer is RECOMMENDED.

Justification: This requirement is to ensure that the timeout is long enough to avoid too-frequent timer refresh packets.

- a) Some UDP protocols using UDP use very short-lived connections. There can be very many such connections; keeping them all in a connections table could cause considerable load on the NAT. Having shorter timers for these specific applications is, therefore, an optimization technique. It is important that the shorter timers applied to specific protocols be used sparingly, and only for protocols using well-known destination ports that are known to have a shorter timer, and that are known not to be used by any applications for other purposes.
- b) Configuration is desirable for adapting to specific networks and troubleshooting.
- c) This default is to avoid too-frequent timer refresh packets.

Some NATs keep the mapping active (i.e., refresh the timer value) when a packet goes from the internal side of the NAT to the external side of the NAT. This is referred to as having a NAT Outbound refresh behavior of "True".

Some NATs keep the mapping active when a packet goes from the external side of the NAT to the internal side of the NAT. This is referred to as having a NAT Inbound Refresh Behavior of "True".

Some NATs keep the mapping active on both, in which case, both properties are "True".

REQ-6: The NAT mapping Refresh Direction MUST have a "NAT Outbound refresh behavior" of "True".

- a) The NAT mapping Refresh Direction MAY have a "NAT Inbound refresh behavior" of "True".

Justification: Outbound refresh is necessary for allowing the client to keep the mapping alive.

- a) Inbound refresh may be useful for applications with no outgoing UDP traffic. However, allowing inbound refresh may allow an external attacker or misbehaving application to keep a mapping alive indefinitely. This may be a security risk. Also, if the process is repeated with different ports, over time, it could use up all the ports on the NAT.

4.4. Conflicting Internal and External IP Address Spaces

Many NATs, particularly consumer-level devices designed to be deployed by nontechnical users, routinely obtain their external IP address, default router, and other IP configuration information for their external interface dynamically from an external network, such as an upstream ISP. The NAT, in turn, automatically sets up its own internal subnet in one of the private IP address spaces assigned to this purpose in [RFC1918], typically providing dynamic IP configuration services for hosts on this internal network.

Auto-configuration of NATs and private networks can be problematic, however, if the NAT's external network is also in RFC 1918 private address space. In a common scenario, an ISP places its customers behind a NAT and hands out private RFC 1918 addresses to them. Some of these customers, in turn, deploy consumer-level NATs, which, in effect, act as "second-level" NATs, multiplexing their own private RFC 1918 IP subnets onto the single RFC 1918 IP address provided by the ISP. There is no inherent guarantee, in this case, that the ISP's "intermediate" privately-addressed network and the customer's internal privately-addressed network will not use numerically identical or overlapping RFC 1918 IP subnets. Furthermore, customers of consumer-level NATs cannot be expected to have the technical

knowledge to prevent this scenario from occurring by manually configuring their internal network with non-conflicting RFC 1918 subnets.

NAT vendors need to design their NATs to ensure that they function correctly and robustly even in such problematic scenarios. One possible solution is for the NAT to ensure that whenever its external link is configured with an RFC 1918 private IP address, the NAT automatically selects a different, non-conflicting RFC 1918 IP subnet for its internal network. A disadvantage of this solution is that, if the NAT's external interface is dynamically configured or re-configured after its internal network is already in use, then the NAT may have to renumber its entire internal network dynamically if it detects a conflict.

An alternative solution is for the NAT to be designed so that it can translate and forward traffic correctly, even when its external and internal interfaces are configured with numerically overlapping IP subnets. In this scenario, for example, if the NAT's external interface has been assigned an IP address P in RFC 1918 space, then there might also be an internal node I having the same RFC 1918 private IP address P. An IP packet with destination address P on the external network is directed at the NAT, whereas an IP packet with the same destination address P on the internal network is directed at node I. The NAT therefore needs to maintain a clear operational distinction between "external IP addresses" and "internal IP addresses" to avoid confusing internal node I with its own external interface. In general, the NAT needs to allow all internal nodes (including I) to communicate with all external nodes having public (non-RFC 1918) IP addresses, or having private IP addresses that do not conflict with the addresses used by its internal network.

REQ-7: A NAT device whose external IP interface can be configured dynamically MUST either (1) automatically ensure that its internal network uses IP addresses that do not conflict with its external network, or (2) be able to translate and forward traffic between all internal nodes and all external nodes whose IP addresses numerically conflict with the internal network.

Justification: If a NAT's external and internal interfaces are configured with overlapping IP subnets, then there is, of course, no way for an internal host with RFC 1918 IP address Q to initiate a direct communication session to an external node having the same RFC 1918 address Q, or to other external nodes with IP addresses that numerically conflict with the internal subnet. Such nodes can still open communication sessions indirectly via NAT traversal techniques, however, with the help of a third-party server, such as a STUN server having a public, non-RFC 1918 IP address. In

this case, nodes with conflicting private RFC 1918 addresses on opposite sides of the second-level NAT can communicate with each other via their respective temporary public endpoints on the main Internet, as long as their common, first-level NAT (e.g., the upstream ISP's NAT) supports hairpinning behavior, as described in Section 6.

5. Filtering Behavior

This section describes various filtering behaviors observed in NATs.

When an internal endpoint opens an outgoing session through a NAT, the NAT assigns a filtering rule for the mapping between an internal IP:port (X:x) and external IP:port (Y:y) tuple.

The key behavior to describe is what criteria are used by the NAT to filter packets originating from specific external endpoints.

Endpoint-Independent Filtering:

The NAT filters out only packets not destined to the internal address and port X:x, regardless of the external IP address and port source (Z:z). The NAT forwards any packets destined to X:x. In other words, sending packets from the internal side of the NAT to any external IP address is sufficient to allow any packets back to the internal endpoint.

Address-Dependent Filtering:

The NAT filters out packets not destined to the internal address X:x. Additionally, the NAT will filter out packets from Y:y destined for the internal endpoint X:x if X:x has not sent packets to Y: any previously (independently of the port used by Y). In other words, for receiving packets from a specific external endpoint, it is necessary for the internal endpoint to send packets first to that specific external endpoint's IP address.

Address and Port-Dependent Filtering:

This is similar to the previous behavior, except that the external port is also relevant. The NAT filters out packets not destined for the internal address X:x. Additionally, the NAT will filter out packets from Y:y destined for the internal endpoint X:x if X:x has not sent packets to Y:y previously. In other words, for receiving packets from a specific external endpoint, it is necessary for the internal endpoint to send packets first to that external endpoint's IP address and port.

REQ-8: If application transparency is most important, it is RECOMMENDED that a NAT have an "Endpoint-Independent Filtering" behavior. If a more stringent filtering behavior is most important, it is RECOMMENDED that a NAT have an "Address-Dependent Filtering" behavior.

- a) The filtering behavior MAY be an option configurable by the administrator of the NAT.

Justification: The recommendation to use Endpoint-Independent Filtering is aimed at maximizing application transparency; in particular, for applications that receive media simultaneously from multiple locations (e.g., gaming), or applications that use rendezvous techniques. However, it is also possible that, in some circumstances, it may be preferable to have a more stringent filtering behavior. Filtering independently of the external endpoint is not as secure: An unauthorized packet could get through a specific port while the port was kept open if it was lucky enough to find the port open. In theory, filtering based on both IP address and port is more secure than filtering based only on the IP address (because the external endpoint could, in reality, be two endpoints behind another NAT, where one of the two endpoints is an attacker). However, such a policy could interfere with applications that expect to receive UDP packets on more than one UDP port. Using Endpoint-Independent Filtering or Address-Dependent Filtering instead of Address and Port-Dependent Filtering on a NAT (say, NAT-A) also has benefits when the other endpoint is behind a non-BEHAVE compliant NAT (say, NAT-B) that does not support REQ-1. When the endpoints use ICE, if NAT-A uses Address and Port-Dependent Filtering, connectivity will require a UDP relay. However, if NAT-A uses Endpoint-Independent Filtering or Address-Dependent Filtering, ICE will ultimately find connectivity without requiring a UDP relay. Having the filtering behavior being an option configurable by the administrator of the NAT ensures that a NAT can be used in the widest variety of deployment scenarios.

6. Hairpinning Behavior

If two hosts (called X1 and X2) are behind the same NAT and exchanging traffic, the NAT may allocate an address on the outside of the NAT for X2, called X2':x2'. If X1 sends traffic to X2':x2', it goes to the NAT, which must relay the traffic from X1 to X2. This is referred to as hairpinning and is illustrated below.

Certain NATs have these ALGs turned on permanently, others have them turned on by default but allow them to be turned off, and others have them turned off by default but allow them to be turned on.

NAT ALGs may interfere with UNSAF methods or protocols that try to be NAT-aware and therefore must be used with extreme caution.

REQ-10: To eliminate interference with UNSAF NAT traversal mechanisms and allow integrity protection of UDP communications, NAT ALGs for UDP-based protocols SHOULD be turned off. Future standards track specifications that define ALGs can update this to recommend the defaults for the ALGs that they define.

- a) If a NAT includes ALGs, it is RECOMMENDED that the NAT allow the NAT administrator to enable or disable each ALG separately.

Justification: NAT ALGs may interfere with UNSAF methods.

- a) This requirement allows the user to enable those ALGs that are necessary to aid in the operation of some applications without enabling ALGs, which interfere with the operation of other applications.

8. Deterministic Properties

The classification of NATs is further complicated by the fact that, under some conditions, the same NAT will exhibit different behaviors. This has been seen on NATs that preserve ports or have specific algorithms for selecting a port other than a free one. If the external port that the NAT wishes to use is already in use by another session, the NAT must select a different port. This results in different code paths for this conflict case, which results in different behavior.

For example, if three hosts X1, X2, and X3 all send from the same port x, through a port preserving NAT with only one external IP address, called X1', the first one to send (i.e., X1) will get an external port of x, but the next two will get x2' and x3' (where these are not equal to x). There are NATs where the External NAT mapping characteristics and the External Filter characteristics change between the X1:x and the X2:x mapping. To make matters worse, there are NATs where the behavior may be the same on the X1:x and X2:x mappings, but different on the third X3:x mapping.

Another example is that some NATs have an "Endpoint-Independent Mapping", combined with "Port Overloading", as long as two endpoints are not establishing sessions to the same external direction, but then switch their behavior to "Address and Port-Dependent Mapping"

without "Port Preservation" upon detection of these conflicting sessions establishments.

Any NAT that changes the NAT Mapping or the Filtering behavior without configuration changes, at any point in time, under any particular conditions, is referred to as a "non-deterministic" NAT. NATs that don't are called "deterministic".

Non-deterministic NATs generally change behavior when a conflict of some sort happens, i.e., when the port that would normally be used is already in use by another mapping. The NAT mapping and External Filtering in the absence of conflict is referred to as the Primary behavior. The behavior after the first conflict is referred to as Secondary and after the second conflict is referred to as Tertiary. No NATs have been observed that change on further conflicts, but it is certainly possible that they exist.

REQ-11: A NAT MUST have deterministic behavior, i.e., it MUST NOT change the NAT translation (Section 4) or the Filtering (Section 5) Behavior at any point in time, or under any particular conditions.

Justification: Non-deterministic NATs are very difficult to troubleshoot because they require more intensive testing. This non-deterministic behavior is the root cause of much of the uncertainty that NATs introduce about whether or not applications will work.

9. ICMP Destination Unreachable Behavior

When a NAT sends a packet toward a host on the other side of the NAT, an ICMP message may be sent in response to that packet. That ICMP message may be sent by the destination host or by any router along the network path. The NAT's default configuration SHOULD NOT filter ICMP messages based on their source IP address. Such ICMP messages SHOULD be rewritten by the NAT (specifically, the IP headers and the ICMP payload) and forwarded to the appropriate internal or external host. The NAT needs to perform this function for as long as the UDP mapping is active. Receipt of any sort of ICMP message MUST NOT destroy the NAT mapping. A NAT that performs the functions described in the paragraph above is referred to as "support ICMP Processing".

There is no significant security advantage to blocking ICMP Destination Unreachable packets. Additionally, blocking ICMP Destination Unreachable packets can interfere with application failover, UDP Path MTU Discovery (see [RFC1191] and [RFC1435]), and traceroute. Blocking any ICMP message is discouraged, and blocking ICMP Destination Unreachable is strongly discouraged.

REQ-12: Receipt of any sort of ICMP message MUST NOT terminate the NAT mapping.

- a) The NAT's default configuration SHOULD NOT filter ICMP messages based on their source IP address.
- b) It is RECOMMENDED that a NAT support ICMP Destination Unreachable messages.

Justification: This is easy to do and is used for many things including MTU discovery and rapid detection of error conditions, and has no negative consequences.

10. Fragmentation of Outgoing Packets

When the MTU of the adjacent link is too small, fragmentation of packets going from the internal side to the external side of the NAT may occur. This can occur if the NAT is doing Point-to-Point over Ethernet (PPPoE), or if the NAT has been configured with a small MTU to reduce serialization delay when sending large packets and small higher-priority packets, or for other reasons.

It is worth noting that many IP stacks do not use Path MTU Discovery with UDP packets.

The packet could have its Don't Fragment bit set to 1 (DF=1) or 0 (DF=0).

REQ-13: If the packet received on an internal IP address has DF=1, the NAT MUST send back an ICMP message "Fragmentation needed and DF set" to the host, as described in [RFC0792].

- a) If the packet has DF=0, the NAT MUST fragment the packet and SHOULD send the fragments in order.

Justification: This is as per RFC 792.

- a) This is the same function a router performs in a similar situation [RFC1812].

11. Receiving Fragmented Packets

For a variety of reasons, a NAT may receive a fragmented packet. The IP packet containing the header could arrive in any fragment, depending on network conditions, packet ordering, and the implementation of the IP stack that generated the fragments.

A NAT that is capable only of receiving fragments in order (that is, with the header in the first packet) and forwarding each of the fragments to the internal host is described as "Received Fragments Ordered".

A NAT that is capable of receiving fragments in or out of order and forwarding the individual fragments (or a reassembled packet) to the internal host is referred to as "Receive Fragments Out of Order". See the Security Considerations section of this document for a discussion of this behavior.

A NAT that is neither of these is referred to as "Receive Fragments None".

REQ-14: A NAT MUST support receiving in-order and out-of-order fragments, so it MUST have "Received Fragment Out of Order" behavior.

- a) A NAT's out-of-order fragment processing mechanism MUST be designed so that fragmentation-based DoS attacks do not compromise the NAT's ability to process in-order and unfragmented IP packets.

Justification: See Security Considerations.

12. Requirements

The requirements in this section are aimed at minimizing the complications caused by NATs to applications, such as realtime communications and online gaming. The requirements listed earlier in the document are consolidated here into a single section.

It should be understood, however, that applications normally do not know in advance if the NAT conforms to the recommendations defined in this section. Peer-to-peer media applications still need to use normal procedures, such as ICE [ICE].

A NAT that supports all the mandatory requirements of this specification (i.e., the "MUST"), is "compliant with this specification". A NAT that supports all the requirements of this specification (i.e., including the "RECOMMENDED") is "fully compliant with all the mandatory and recommended requirements of this specification".

- REQ-1: A NAT MUST have an "Endpoint-Independent Mapping" behavior.
- REQ-2: It is RECOMMENDED that a NAT have an "IP address pooling" behavior of "Paired". Note that this requirement is not applicable to NATs that do not support IP address pooling.
- REQ-3: A NAT MUST NOT have a "Port assignment" behavior of "Port overloading".
- a) If the host's source port was in the range 0-1023, it is RECOMMENDED the NAT's source port be in the same range. If the host's source port was in the range 1024-65535, it is RECOMMENDED that the NAT's source port be in that range.
- REQ-4: It is RECOMMENDED that a NAT have a "Port parity preservation" behavior of "Yes".
- REQ-5: A NAT UDP mapping timer MUST NOT expire in less than two minutes, unless REQ-5a applies.
- a) For specific destination ports in the well-known port range (ports 0-1023), a NAT MAY have shorter UDP mapping timers that are specific to the IANA-registered application running over that specific destination port.
- b) The value of the NAT UDP mapping timer MAY be configurable.
- c) A default value of five minutes or more for the NAT UDP mapping timer is RECOMMENDED.
- REQ-6: The NAT mapping Refresh Direction MUST have a "NAT Outbound refresh behavior" of "True".
- a) The NAT mapping Refresh Direction MAY have a "NAT Inbound refresh behavior" of "True".
- REQ-7 A NAT device whose external IP interface can be configured dynamically MUST either (1) Automatically ensure that its internal network uses IP addresses that do not conflict with its external network, or (2) Be able to translate and forward traffic between all internal nodes and all external nodes whose IP addresses numerically conflict with the internal network.
- REQ-8: If application transparency is most important, it is RECOMMENDED that a NAT have "Endpoint-Independent Filtering" behavior. If a more stringent filtering behavior is most important, it is RECOMMENDED that a NAT have "Address-Dependent Filtering" behavior.

- a) The filtering behavior MAY be an option configurable by the administrator of the NAT.

REQ-9: A NAT MUST support "Hairpinning".

- a) A NAT Hairpinning behavior MUST be "External source IP address and port".

REQ-10: To eliminate interference with UNSAF NAT traversal mechanisms and allow integrity protection of UDP communications, NAT ALGs for UDP-based protocols SHOULD be turned off. Future standards track specifications that define an ALG can update this to recommend the ALGs on which they define default.

- a) If a NAT includes ALGs, it is RECOMMENDED that the NAT allow the NAT administrator to enable or disable each ALG separately.

REQ-11: A NAT MUST have deterministic behavior, i.e., it MUST NOT change the NAT translation (Section 4) or the Filtering (Section 5) Behavior at any point in time, or under any particular conditions.

REQ-12: Receipt of any sort of ICMP message MUST NOT terminate the NAT mapping.

- a) The NAT's default configuration SHOULD NOT filter ICMP messages based on their source IP address.
- b) It is RECOMMENDED that a NAT support ICMP Destination Unreachable messages.

REQ-13 If the packet received on an internal IP address has DF=1, the NAT MUST send back an ICMP message "Fragmentation needed and DF set" to the host, as described in [RFC0792].

- a) If the packet has DF=0, the NAT MUST fragment the packet and SHOULD send the fragments in order.

REQ-14: A NAT MUST support receiving in-order and out-of-order fragments, so it MUST have "Received Fragment Out of Order" behavior.

- a) A NAT's out-of-order fragment processing mechanism MUST be designed so that fragmentation-based DoS attacks do not compromise the NAT's ability to process in-order and unfragmented IP packets.

13. Security Considerations

NATs are often deployed to achieve security goals. Most of the recommendations and requirements in this document do not affect the security properties of these devices, but a few of them do have security implications and are discussed in this section.

This document recommends that the timers for mapping be refreshed on outgoing packets (see REQ-6) and does not make recommendations about whether or not inbound packets should update the timers. If inbound packets update the timers, an external attacker can keep the mapping alive forever and attack future devices that may end up with the same internal address. A device that was also the DHCP server for the private address space could mitigate this by cleaning any mappings when a DHCP lease expired. For unicast UDP traffic (the scope of this document), it may not seem relevant to support inbound timer refresh; however, for multicast UDP, the question is harder. It is expected that future documents discussing NAT behavior with multicast traffic will refine the requirements around handling of the inbound refresh timer. Some devices today do update the timers on inbound packets.

This document recommends that the NAT filters be specific to the external IP address only (see REQ-8) and not to the external IP address and UDP port. It can be argued that this is less secure than using the IP and port. Devices that wish to filter on IP and port do still comply with these requirements.

Non-deterministic NATs are risky from a security point of view. They are very difficult to test because they are, well, non-deterministic. Testing by a person configuring one may result in the person thinking it is behaving as desired, yet under different conditions, which an attacker can create, the NAT may behave differently. These requirements recommend that devices be deterministic.

This document requires that NATs have an "external NAT mapping is endpoint independent" behavior. This does not reduce the security of devices. Which packets are allowed to flow across the device is determined by the external filtering behavior, which is independent of the mapping behavior.

When a fragmented packet is received from the external side, and the packets are out of order so that the initial fragment does not arrive first, many systems simply discard the out-of-order packets. Moreover, since some networks deliver small packets ahead of large ones, there can be many out-of-order fragments. NATs that are capable of delivering these out-of-order packets are possible, but they need to store the out-of-order fragments, which can open up a

Denial-of-Service (DoS) opportunity, if done incorrectly. Fragmentation has been a tool used in many attacks, some involving passing fragmented packets through NATs, and others involving DoS attacks based on the state needed to reassemble the fragments. NAT implementers should be aware of [RFC3128] and [RFC1858].

14. IAB Considerations

The IAB has studied the problem of "Unilateral Self Address Fixing", which is the general process by which a client attempts to determine its address in another realm on the other side of a NAT through a collaborative protocol reflection mechanism [RFC3424].

This specification does not, in itself, constitute an UNSAF application. It consists of a series of requirements for NATs aimed at minimizing the negative impact that those devices have on peer-to-peer media applications, especially when those applications are using UNSAF methods.

Section 3 of UNSAF lists several practical issues with solutions to NAT problems. This document makes recommendations to reduce the uncertainty and problems introduced by these practical issues with NATs. In addition, UNSAF lists five architectural considerations. Although this is not an UNSAF proposal, it is interesting to consider the impact of this work on these architectural considerations.

Arch-1: The scope of this is limited to UDP packets in NATs like the ones widely deployed today. The "fix" helps constrain the variability of NATs for true UNSAF solutions such as STUN.

Arch-2: This will exit at the same rate that NATs exit. It does not imply any protocol machinery that would continue to live after NATs were gone, or make it more difficult to remove them.

Arch-3: This does not reduce the overall brittleness of NATs, but will hopefully reduce some of the more outrageous NAT behaviors and make it easier to discuss and predict NAT behavior in given situations.

Arch-4: This work and the results [RESULTS] of various NATs represent the most comprehensive work at IETF on what the real issues are with NATs for applications like VoIP. This work and STUN have pointed out, more than anything else, the brittleness NATs introduce and the difficulty of addressing these issues.

Arch-5: This work and the test results [RESULTS] provide a reference model for what any UNSAF proposal might encounter in deployed NATs.

15. Acknowledgments

The editor would like to acknowledge Bryan Ford, Pyda Srisuresh, and Dan Keigel for their multiple contributions on peer-to-peer communications across a NAT. Dan Wing contributed substantial text on IP fragmentation and ICMP behavior. Thanks to Rohan Mahy, Jonathan Rosenberg, Mary Barnes, Melinda Shore, Lyndsay Campbell, Geoff Huston, Jiri Kuthan, Harald Welte, Steve Casner, Robert Sanders, Spencer Dawkins, Saikat Guha, Christian Huitema, Yutaka Takeda, Paul Hoffman, Lisa Dusseault, Pekka Savola, Peter Koch, Jari Arkko, and Alfred Hoenes for their contributions.

16. References

16.1. Normative References

- [RFC0768] Postel, J., "User Datagram Protocol", STD 6, RFC 768, August 1980.
- [RFC0791] Postel, J., "Internet Protocol", STD 5, RFC 791, September 1981.
- [RFC2119] Bradner, S., "Key words for use in RFCs to Indicate Requirement Levels", BCP 14, RFC 2119, March 1997.

16.2. Informative References

- [RFC0792] Postel, J., "Internet Control Message Protocol", STD 5, RFC 792, September 1981.
- [RFC1191] Mogul, J. and S. Deering, "Path MTU discovery", RFC 1191, November 1990.
- [RFC1435] Knowles, S., "IESG Advice from Experience with Path MTU Discovery", RFC 1435, March 1993.
- [RFC1812] Baker, F., "Requirements for IP Version 4 Routers", RFC 1812, June 1995.
- [RFC1858] Ziemba, G., Reed, D., and P. Traina, "Security Considerations for IP Fragment Filtering", RFC 1858, October 1995.

- [RFC1918] Rekhter, Y., Moskowitz, R., Karrenberg, D., Groot, G., and E. Lear, "Address Allocation for Private Internets", BCP 5, RFC 1918, February 1996.
- [RFC2460] Deering, S. and R. Hinden, "Internet Protocol, Version 6 (IPv6) Specification", RFC 2460, December 1998.
- [RFC2623] Eisler, M., "NFS Version 2 and Version 3 Security Issues and the NFS Protocol's Use of RPCSEC_GSS and Kerberos V5", RFC 2623, June 1999.
- [RFC2663] Srisuresh, P. and M. Holdrege, "IP Network Address Translator (NAT) Terminology and Considerations", RFC 2663, August 1999.
- [RFC3022] Srisuresh, P. and K. Egevang, "Traditional IP Network Address Translator (Traditional NAT)", RFC 3022, January 2001.
- [RFC3027] Holdrege, M. and P. Srisuresh, "Protocol Complications with the IP Network Address Translator", RFC 3027, January 2001.
- [RFC3128] Miller, I., "Protection Against a Variant of the Tiny Fragment Attack (RFC 1858)", RFC 3128, June 2001.
- [RFC3261] Rosenberg, J., Schulzrinne, H., Camarillo, G., Johnston, A., Peterson, J., Sparks, R., Handley, M., and E. Schooler, "SIP: Session Initiation Protocol", RFC 3261, June 2002.
- [RFC3424] Daigle, L. and IAB, "IAB Considerations for UNilateral Self-Address Fixing (UNSAF) Across Network Address Translation", RFC 3424, November 2002.
- [RFC3489] Rosenberg, J., Weinberger, J., Huitema, C., and R. Mahy, "STUN - Simple Traversal of User Datagram Protocol (UDP) Through Network Address Translators (NATs)", RFC 3489, March 2003.
- [RFC3550] Schulzrinne, H., Casner, S., Frederick, R., and V. Jacobson, "RTP: A Transport Protocol for Real-Time Applications", STD 64, RFC 3550, July 2003.
- [RFC3605] Huitema, C., "Real Time Control Protocol (RTCP) attribute in Session Description Protocol (SDP)", RFC 3605, October 2003.

- [RFC4380] Huitema, C., "Teredo: Tunneling IPv6 over UDP through Network Address Translations (NATs)", RFC 4380, February 2006.
- [RFC3489bis] Rosenberg, J., "Simple Traversal Underneath Network Address Translators (NAT) (STUN)", Work in Progress, October 2006.
- [ICE] Rosenberg, J., "Interactive Connectivity Establishment (ICE): A Methodology for Network Address Translator (NAT) Traversal for Offer/Answer Protocols", Work in Progress, October 2006.
- [RESULTS] Jennings, C., "NAT Classification Test Results", Work in Progress, October 2006.
- [TURN] Rosenberg, J., "Obtaining Relay Addresses from Simple Traversal Underneath NAT (STUN)", Work in Progress, October 2006.
- [ITU.H323] "Packet-based Multimedia Communications Systems", ITU-T Recommendation H.323, July 2003.

Authors' Addresses

Francois Audet (editor)
Nortel Networks
4655 Great America Parkway
Santa Clara, CA 95054
US

Phone: +1 408 495 2456
EMail: audet@nortel.com

Cullen Jennings
Cisco Systems
170 West Tasman Drive
MS: SJC-21/2
San Jose, CA 95134
US

Phone: +1 408 902 3341
EMail: fluffy@cisco.com

Full Copyright Statement

Copyright (C) The IETF Trust (2007).

This document is subject to the rights, licenses and restrictions contained in BCP 78, and except as set forth therein, the authors retain all their rights.

This document and the information contained herein are provided on an "AS IS" basis and THE CONTRIBUTOR, THE ORGANIZATION HE/SHE REPRESENTS OR IS SPONSORED BY (IF ANY), THE INTERNET SOCIETY, THE IETF TRUST AND THE INTERNET ENGINEERING TASK FORCE DISCLAIM ALL WARRANTIES, EXPRESS OR IMPLIED, INCLUDING BUT NOT LIMITED TO ANY WARRANTY THAT THE USE OF THE INFORMATION HEREIN WILL NOT INFRINGE ANY RIGHTS OR ANY IMPLIED WARRANTIES OF MERCHANTABILITY OR FITNESS FOR A PARTICULAR PURPOSE.

Intellectual Property

The IETF takes no position regarding the validity or scope of any Intellectual Property Rights or other rights that might be claimed to pertain to the implementation or use of the technology described in this document or the extent to which any license under such rights might or might not be available; nor does it represent that it has made any independent effort to identify any such rights. Information on the procedures with respect to rights in RFC documents can be found in BCP 78 and BCP 79.

Copies of IPR disclosures made to the IETF Secretariat and any assurances of licenses to be made available, or the result of an attempt made to obtain a general license or permission for the use of such proprietary rights by implementers or users of this specification can be obtained from the IETF on-line IPR repository at <http://www.ietf.org/ipr>.

The IETF invites any interested party to bring to its attention any copyrights, patents or patent applications, or other proprietary rights that may cover technology that may be required to implement this standard. Please address the information to the IETF at ietf-ipr@ietf.org.

Acknowledgement

Funding for the RFC Editor function is currently provided by the Internet Society.

