

SOURCE:	ARIB
TITLE:	ARIB's Activities on IMT-2000 and IMT-Advanced
AGENDA ITEM:	Joint 4.1
CONTACT:	Kohei SATOH (satoh@arib.or.jp)



gsc11_joint_16r1

ARIB's Activities on IMT-2000 and IMT-Advanced

**Association of Radio Industries and Businesses
(ARIB)**

May 29th, 2006

***GSC: Standardization Advancing Global
Communications***

Outline of the Presentation

- ◆ **Japan's Cellular Market and Current Status of IMT-2000**
- ◆ **Activities on IMT-Advanced in mITF**
 - Outline of Mobile IT Forum
 - Activities of Fourth Generation Mobile Communications Committee
- ◆ **Overview of Advanced Wireless Communications Study Committee**
 - Back Ground of New Study Committee
 - Structural Organization of Study Committee
 - Activities on Study Committee
- ◆ **Summary of Activities in GSC-11 on Mapping Standards for "Systems beyond IMT-2000"**

GSC: Standardization Advancing Global Communications

◆ **Japan's Cellular Market and
Current Status of IMT-2000**

Mobile phone subscribers in Japan

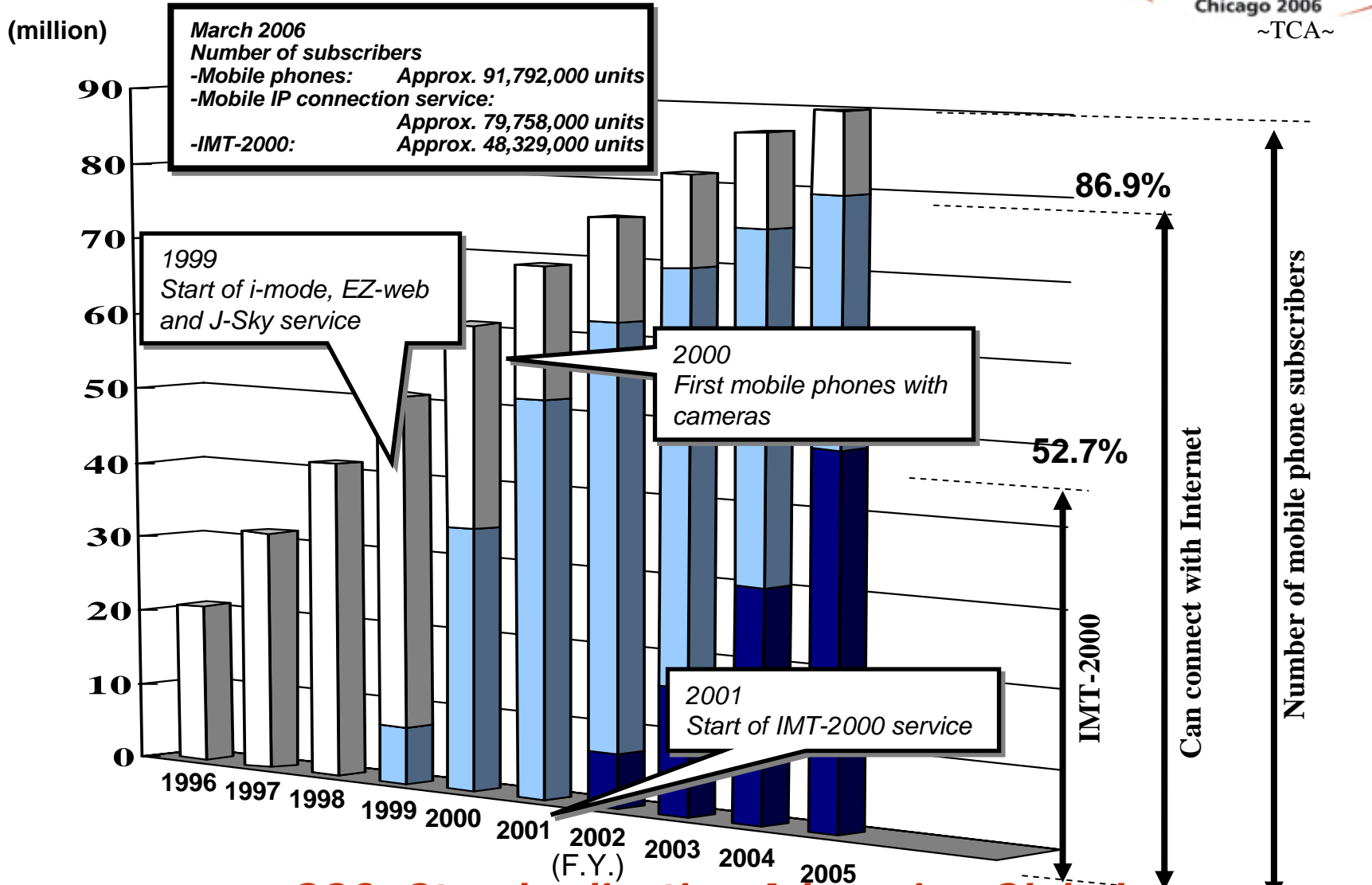

GSC: Standardization Advancing Global Communications

Growth of IMT-2000 subscribers

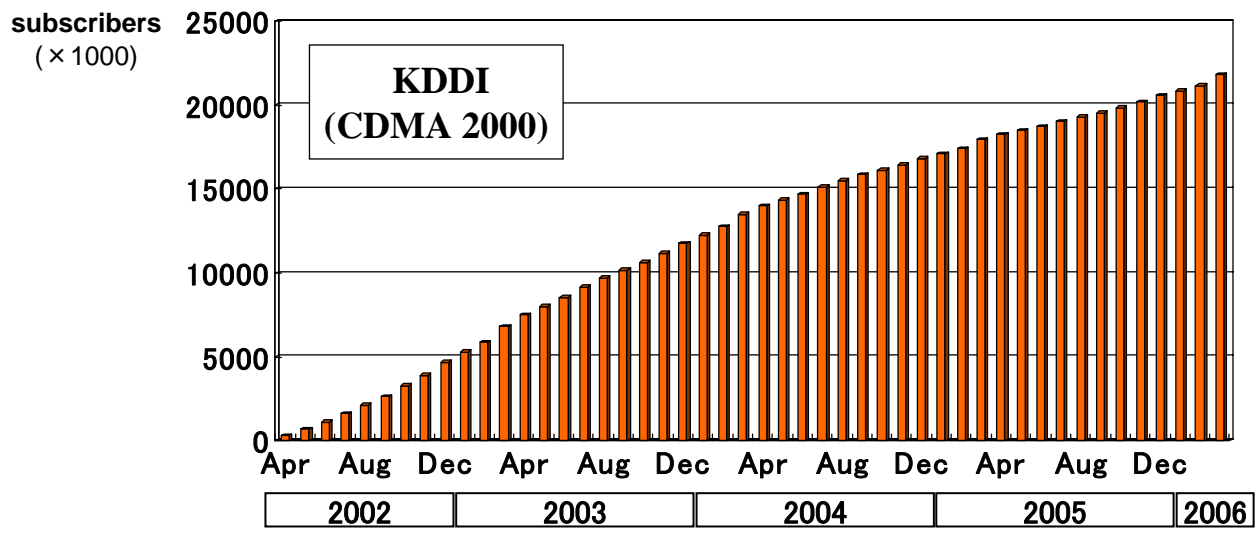
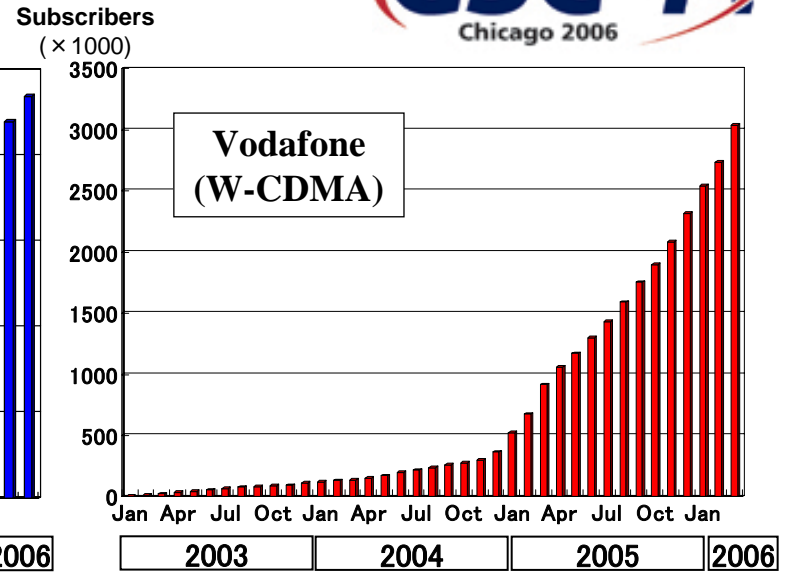
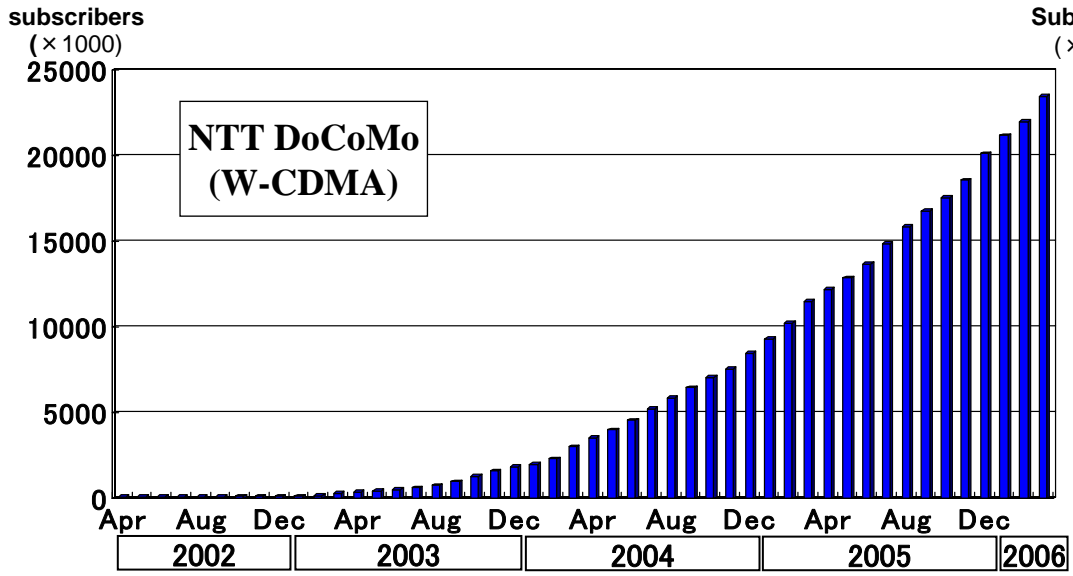

GSC: Standardization Advancing Global Communications

Deployment of IMT-2000 in Japan

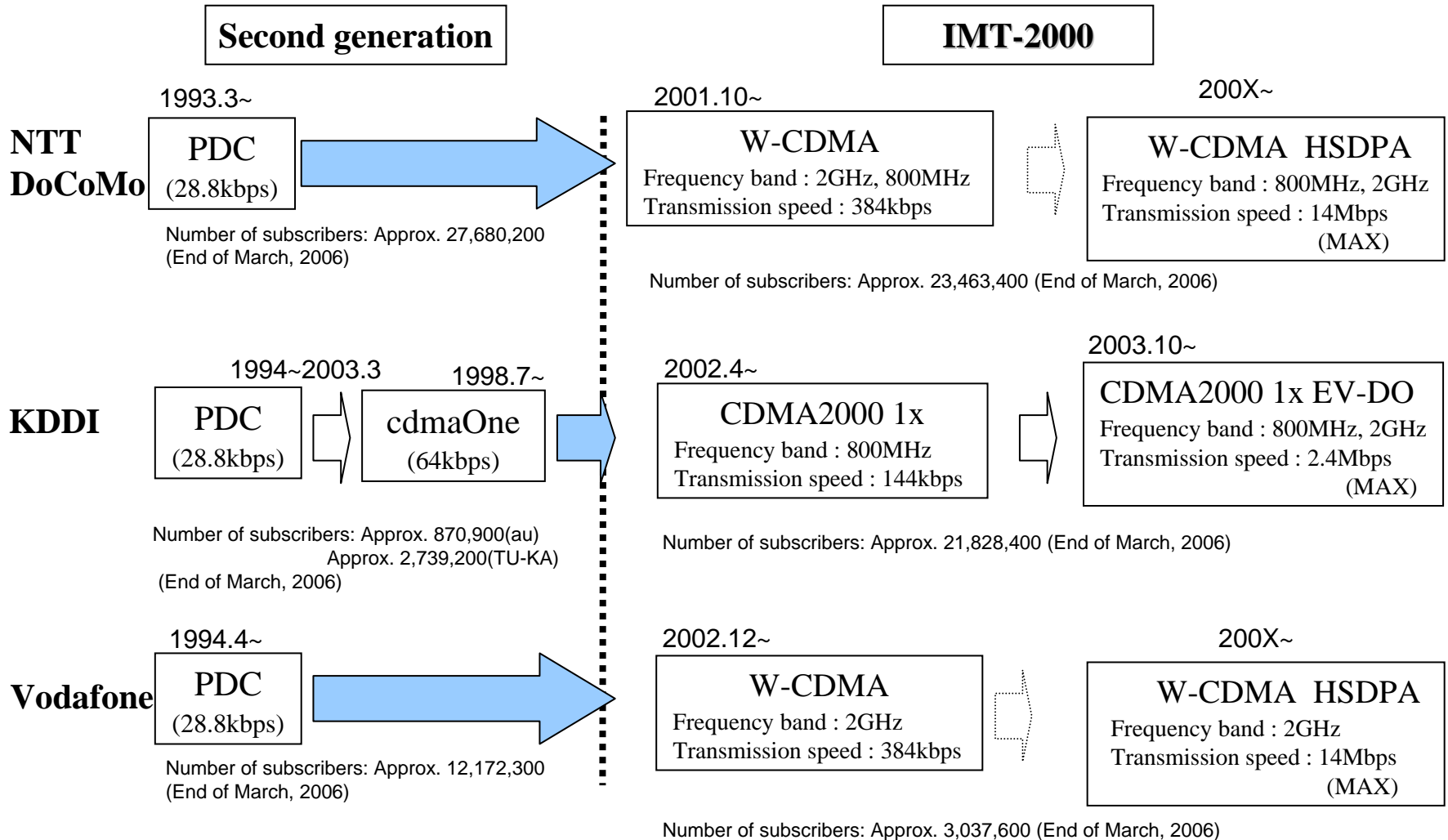

GSC: Standardization Advancing Global Communications

IMT-2000 Standardization Activities in ARIB



- ARIB establishes its standards on CDMA-DS and CDMA-MC based on 3GPPs specifications around every 3-4 months.
(CDMA-DS: STD-T63, TR-T12 Ver.4.80)
(CDMA-MC:STD-T64, TR-T13 Ver.4.00)
- December 2005 Version of Release 6 3GPP specifications and April 2006 of Release 4 3GPP2 specifications have already been transposed to ARIB standards.

GSC: Standardization Advancing Global Communications

◆ **Activities on IMT-Advanced in mITF**

Mobile IT Forum (mITF)

- **Objectives:**

To realize an early implementation of Future Mobile Communication Systems including Systems beyond IMT-2000 and mobile commerce, the Forum conducts studies and researches on technologies and standardization.

- **Established on June 25, 2001(Secretary:ARIB)**

- **Members (As of End of March 2006)**

- General members 86
- Individual members 12
- Special members 2 (ARIB and TTC)

- **Current main activities**

- Future Mobile Communications Systems (IMT-Advanced)
- Mobile Commerce

<http://www.mitf.org/>

GSC: Standardization Advancing Global Communications

Organizational Structure of mITF

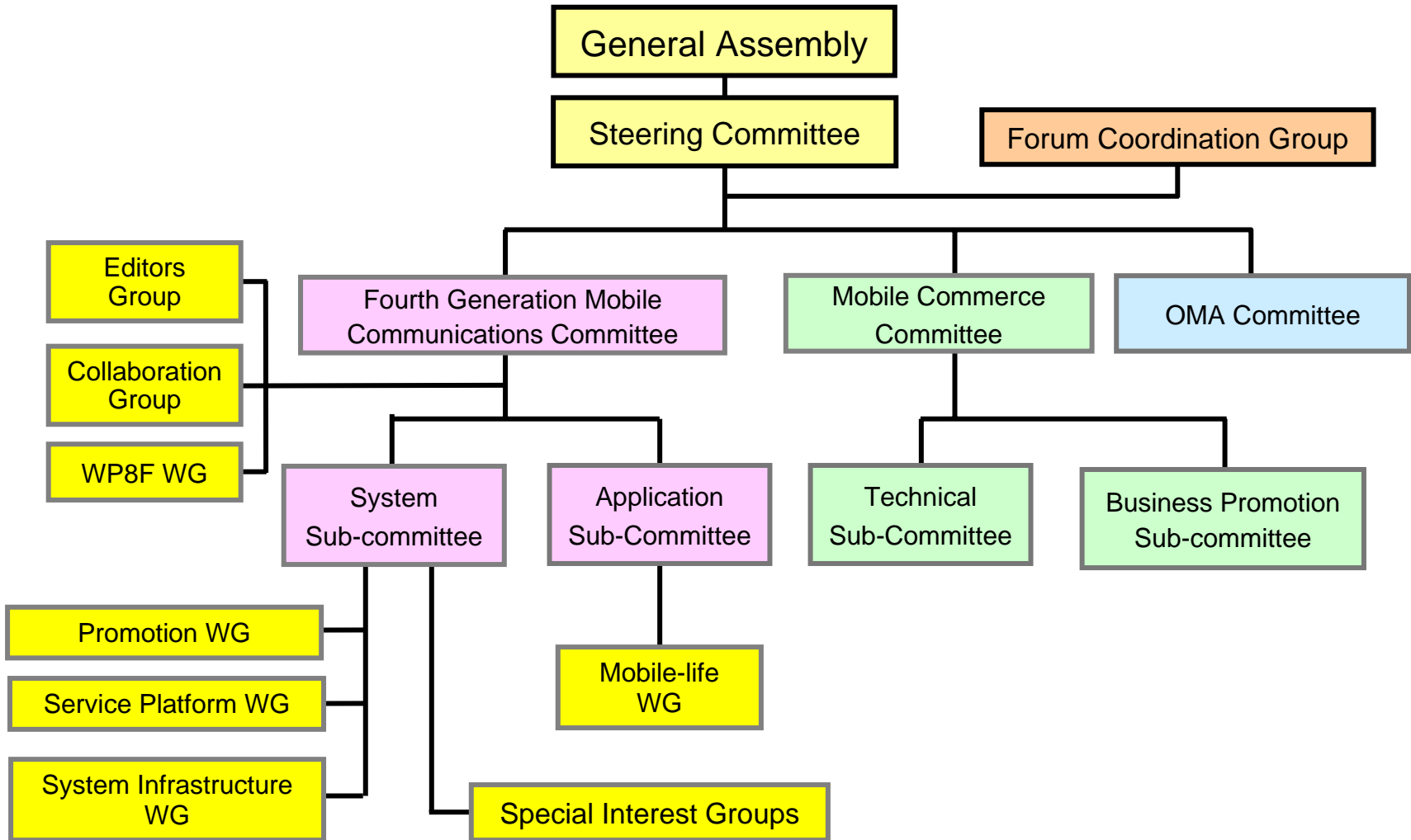

GSC: Standardization Advancing Global Communications

- **Objectives**

- Clarify the system configuration and applications of 4G systems
- Propose concrete activities envisioning 4G commercial introduction around 2010
- Facilitate R&D activities and standardization activities by the industry and academia

- **System Sub-Committee**

- **Facilitate the R&D and standardization of the 4G systems** to realize a world's leading mobile IT
- Contribute to creating mobile business markets ten years ahead

- **Application Sub-Committee**

- Analyze the business surrounding the 4G system ten years ahead, envisioning mobile life style from users' point of view
- Clarify requirements for system, functions and other aspects

Work Procedure in the System Sub-Committee

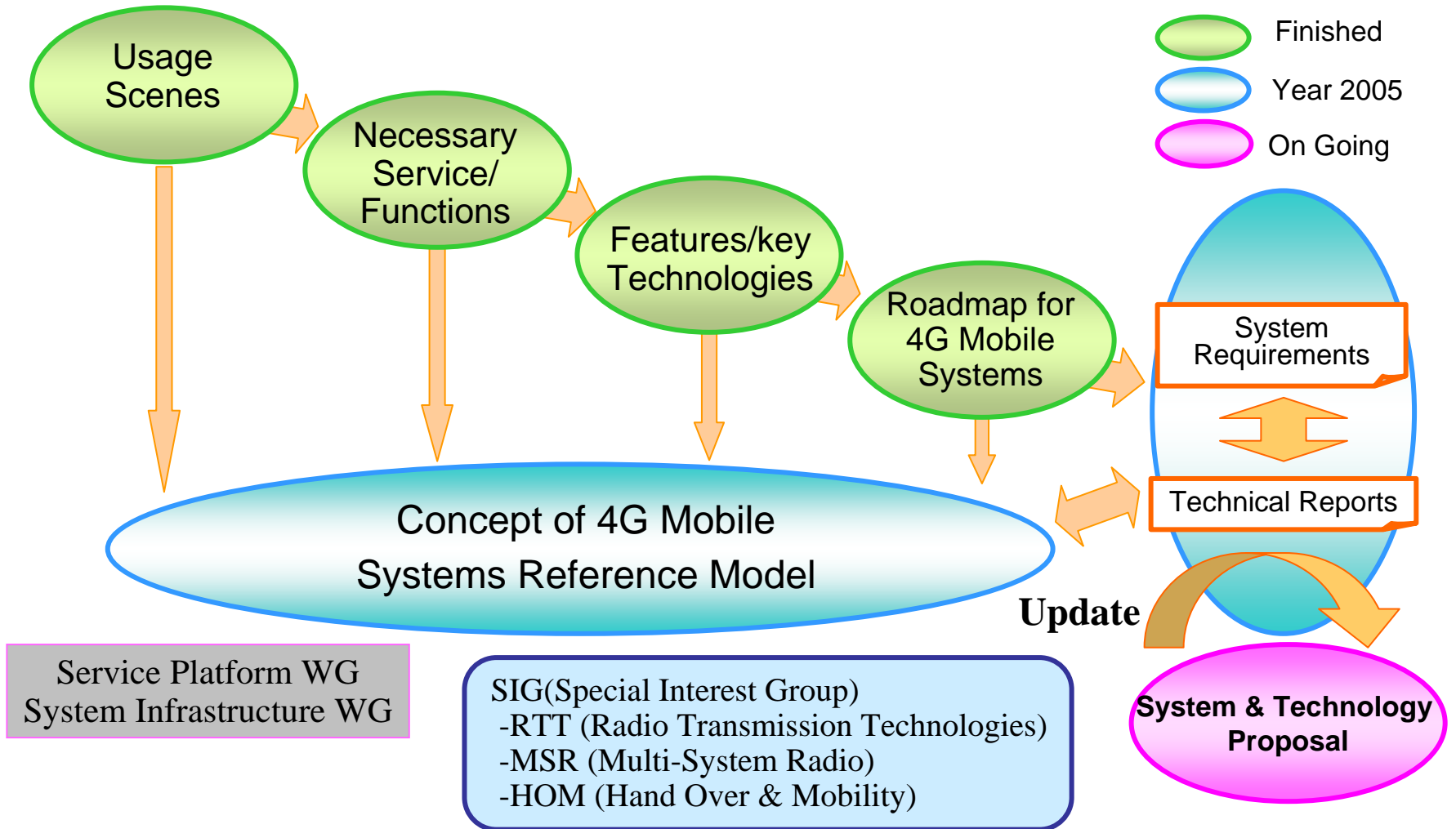

Four Domains of Reference Model

1. Service & Application

- Commonly accessible both from the New and existing access systems
- Agent supports smooth provisioning of services and applications

2. Service Platform

- Provides the service foundation to help realize the services and applications offered by Service & Application Domain
- multimedia features
- high-speed/large-capacity network features
- network QoS features

3. Packet-based Core Network

- Independent from the access systems
- Enables interconnection between 4G mobile systems as well as other access systems (e.g., 2G/3G cellular, W-LAN, DSRC, digital broadcasting, and other IP networks, etc.), to provide users with seamless access

4. New Radio Access

- New Mobile Access Capability
- New Nomadic Wireless Access Capability
- Moving Network Capability

Three Categories of Service Platform Reference Model



1. User Convenience

- User interface
- Agent
- Terminal processing capability / usable hours / external interface
- Terminal reconfigurability

2. Advanced Service

- High-quality multimedia
- Information input
- Location/navigation
- Remote sensing/control

3. System Management

- QoS
- Security / authentication / authorization / accounting
- Database / remote server
- Society / environment adaptation feature

GSC: Standardization Advancing Global Communications

System Infrastructure Reference model

5 Scenarios for Radio Access (example)

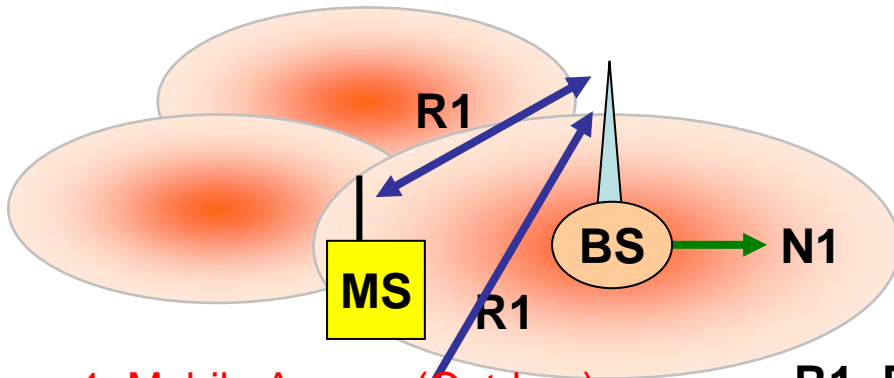

1. Mobile Access (Outdoor)

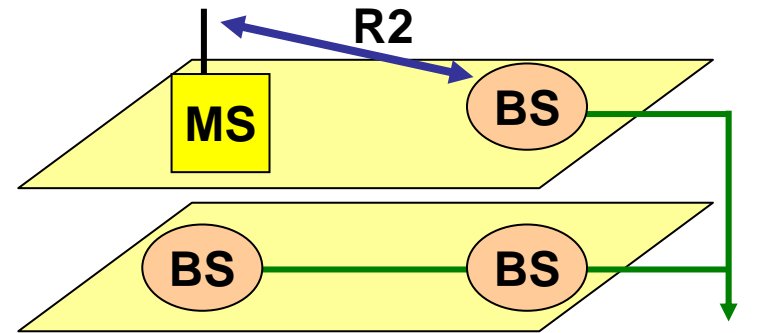

2. Mobile Access (Indoor) / Nomadic Wireless Access

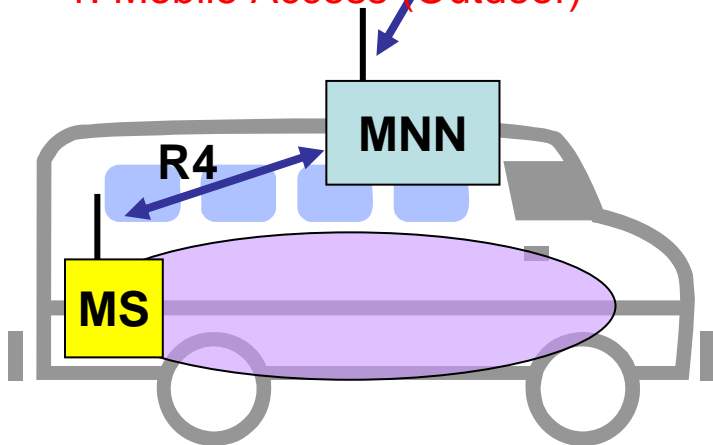

4. Moving Network

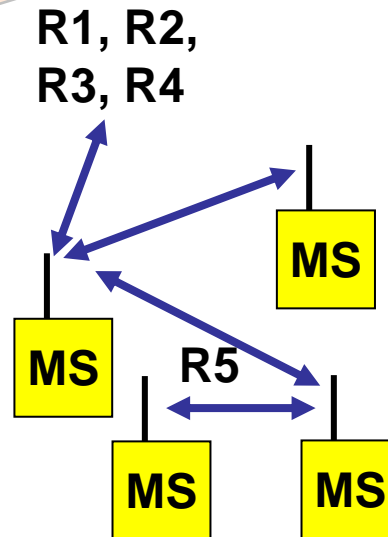

5. Ad Hoc Network

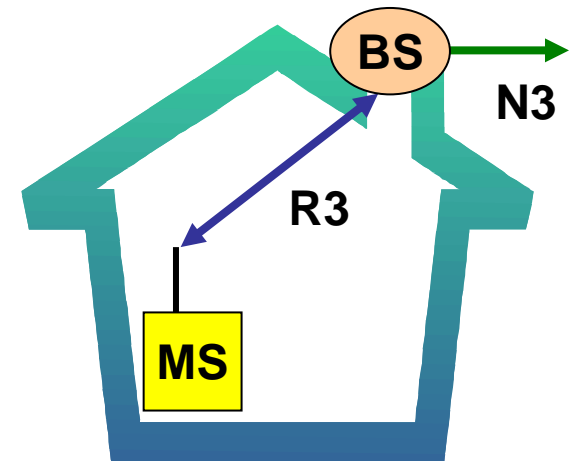

3. Nomadic Wireless Access

MNN: Moving Network Node

Rn: Radio Interface

Nn: Network Interface

GSC: Standardization Advancing Global Communications

Technical Survey Report



- **Objective**

By analyzing currently available technologies and developing technologies in the near future, the study report will be used as a reference materials for requirement document.

- **Technical roadmap** is attached.

- **Status**

The Japanese version is available in

http://www.mitf.org/public_j/archives/index.html

The English version is available in

http://www.mitf.org/public_e/archives/index.html

GSC: Standardization Advancing Global Communications

Contents of Technical Survey Report (1/2)



- **Service Platform**
 - **Terminal related technologies**
 - User interface/ Multimedia / Terminal agent & Intelligent processing / Processing capability / Reconfigurability
 - **Transport technologies**
 - QoS control / Policy routing / VPN / Adhoc network / Network security
 - **Service platform technologies**
 - Authentication and security / Location / Agent / Semantic web / Information appliances and WLAN / Broadcast
 - **Application technologies**
 - User interface / Location based application / Virtual reality / Ubiquitous application / Mobile agents
 - **Application on social and environmental requirements**
 - Emergency medical / Disaster relief / Environment / Trends in emergency communication

Contents of Technical Survey Report (2/2)



- **System Infrastructure**
 - High-speed large-capacity wireless transmission
 - VSF-OFCDM / SCS-MC-CDMA / OFDMA / IFDMA / Ad hoc network / Adaptive-antenna / MIMO
 - Multi system wireless terminal technologies
 - E2R / SDR / multi-band RF
 - Quality of Service
 - Scheduler / Wireless-QoS
 - Handover & Mobility control
 - High speed HO / Mobility control / Mobile IPv6
 - Seamless networking
 - Interworking
 - Multicast / Broadcast

4G Mobile System Requirement Document



- **Objective**

“4G system requirement document” will include the requirements for four domains of the mITF reference model for 4G mobile system.

- **Status**

The English version (V1.1) is available in

http://www.mitf.org/public_e/archives/index.html

The Japanese version (V1.1) is available in

http://www.mitf.org/public_j/archives/index.html

Contents of 4G Mobile System Requirements Doc.



1. Introduction
2. Scope
3. Trend of Wireless Communications Services
4. Spectrum Requirements
5. System Requirements
 - 5.1 Radio Use Environments
 - 5.2 End-User Requirements
 - 5.3 Requirements for Network Operators
6. System migration, Interworking
 - 6.1 System migration
 - 6.2 Interworking
7. Requirements for Terminal-Related Technologies
 - 7.1 User Interface Requirements
 - 7.2 Multimedia-Related Requirements
 - 7.3 Requirements for Terminal Agent and Intelligent Processing
 - 7.4 Requirements for Terminal Processing Capability
 - 7.5 Requirements for Reconfigurability
8. Requirements for Transport-Related Technologies
 - 8.1 QoS Requirements
 - 8.2 Requirements for VPN
 - 8.3 System Requirements Against Network Attacks
 - 8.4 Requirements for Ad Hoc Networks
9. Requirements for Service Platform-Related Technologies
 - 9.1 Authentication and Security Technologies
 - 9.2 Location Provisioning Technologies
 - 9.3 Requirements for Network Connection Agent
 - 9.4 Semantic Web
 - 9.5 Requirements for Home Information Appliances and Wireless LAN
 - 9.6 Requirements for Broadcast Services
10. Requirements for Application-Related Technologies
 - 10.1 Requirements for Advanced User Interface
 - 10.2 Requirements for Location-Based Applications
 - 10.3 Requirements for Virtual Reality Applications
 - 10.4 Requirements for Ubiquitous Applications
 - 10.5 Requirements for Agent Applications

Work Flow of Application Sub-Committee

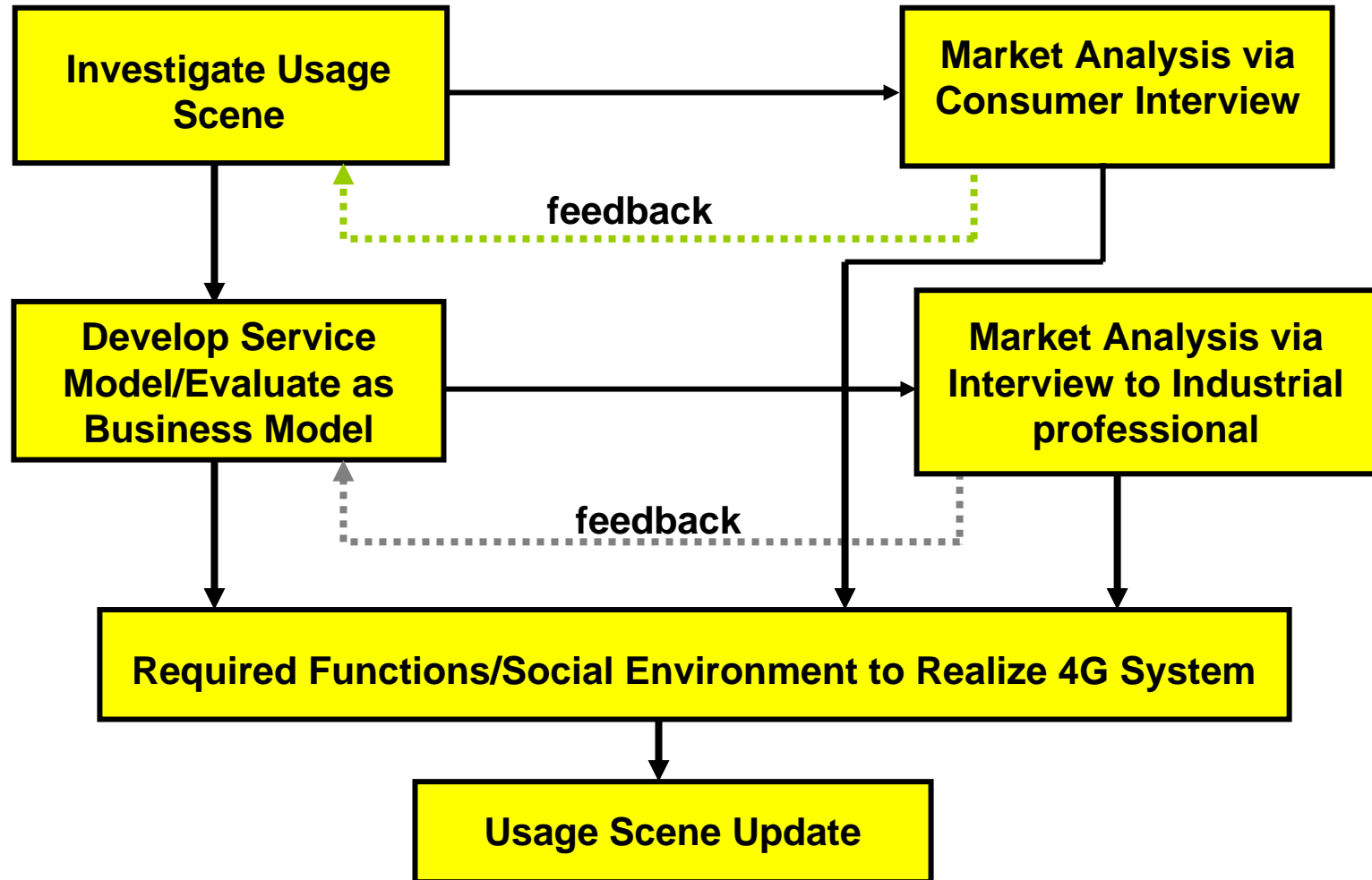

4G Application Research Seminar



Whole Theme

The present and future of "mobile" that user requests.
 What is the breakthrough requested from the user side for 4G mobile systems?

Background of theme setting

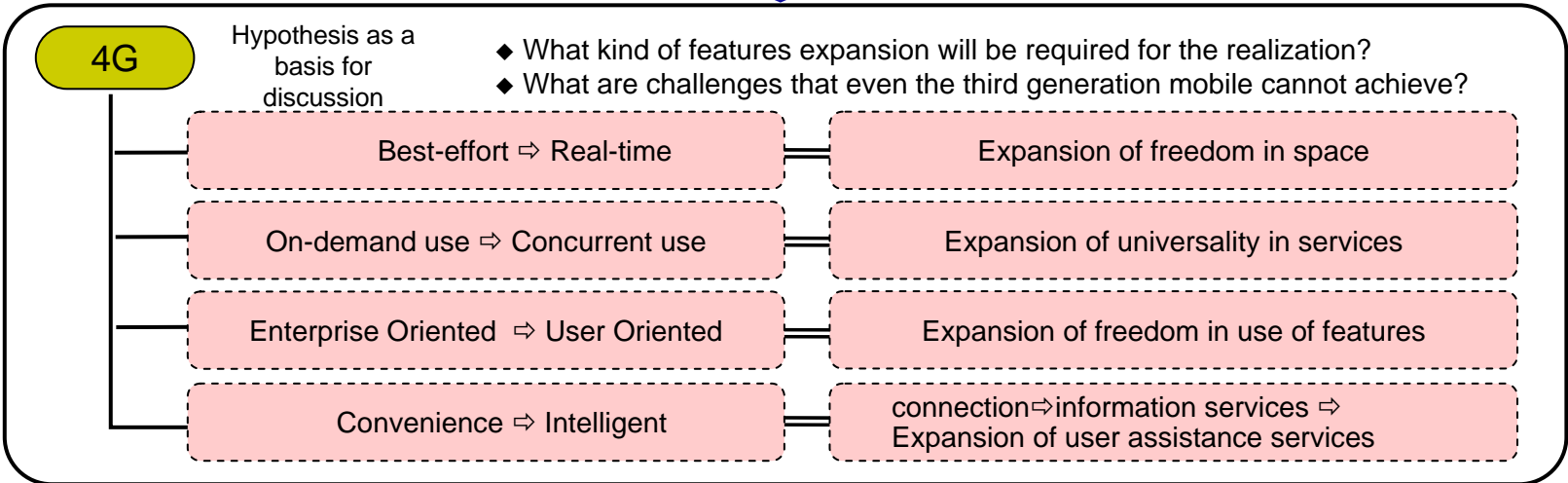
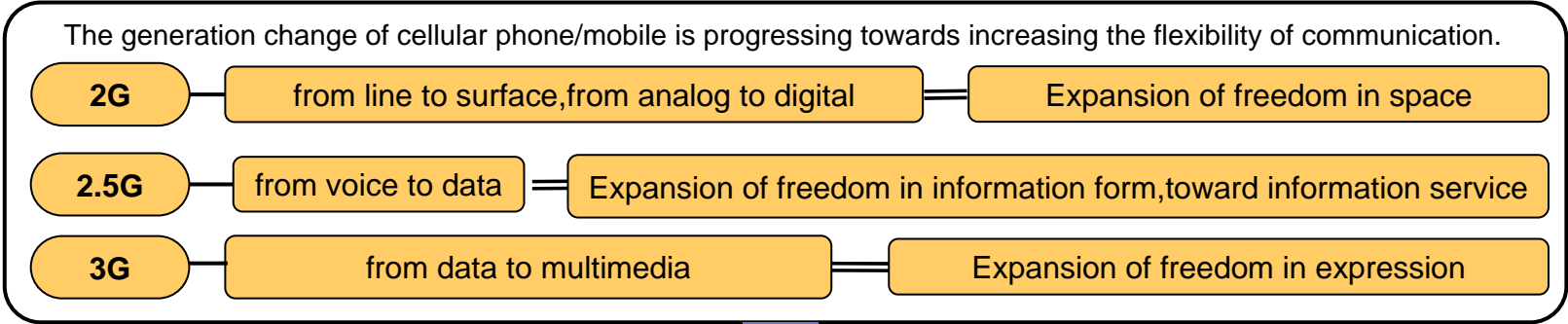

GSC: Standardization Advancing Global Communications

Requirements from User's Perspectives



◆ End User

- Standardization of protocols
- Easy-to-use HMI
- Voice recognition/synthesis
- Agent feature
- Multi-connectivity
- Database/search engine
- Highly reliable information communication
- Personal authentication and data disclosure

◆ Maker

- Copyrights
- Standardization

◆ Operator

- Advanced authentication
- System compatibility
- Information communication with high level of security

◆ Service Provider

- User authentication
- User authentication
- Copyrights
- Protection of intellectual property rights
- Mechanism that prevents image storage
- Privacy protection
- Security
- QoS
- Highly reliable information communication
- Information communication with high level of security and reliability

◆ Public Service Provider

- Safety
- Cryptography features
- Unification between various models
- Ubiquitous environment
- Authentication system
- Highly reliable information communication
- Mobile networks that works in disasters

New illustrations of 4G Mobile Service (Example)

In the morning

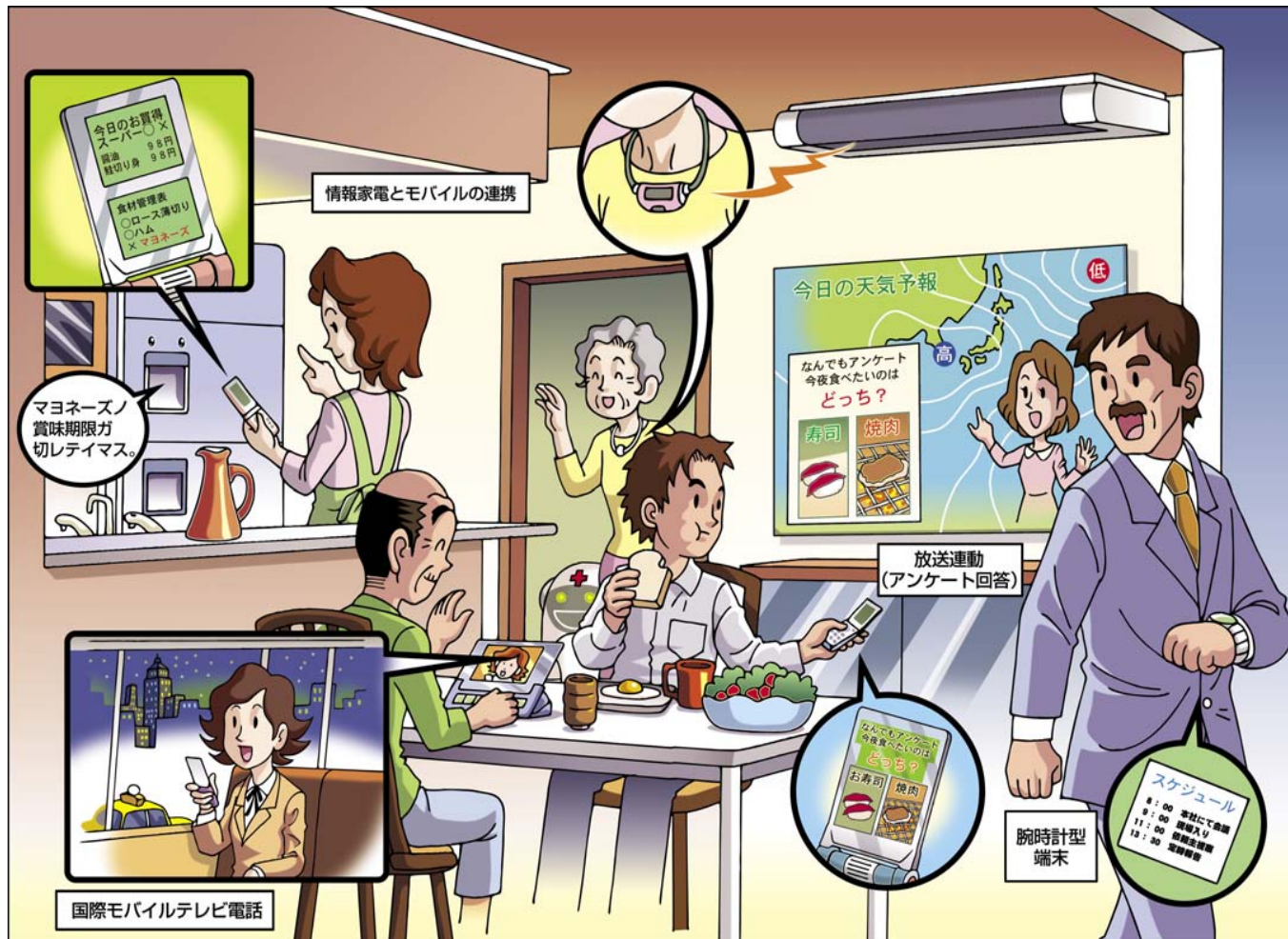

- Interaction of mobile with home information appliances, digital TV
- Interaction of RFID
- Presence function
- Wearable terminal
- Download of broadcasting contents to mobile communication system
- Real time monitoring of physical conditions

Report of the Committee



Flying Carpet II

-Towards the 4th Generation Mobile Communications Systems-



This brochure was named “Flying Carpet” because we thought with its magical power to fly the sky, we might be able to foresee our new lives and the underlying mobile technologies in a decade from now.

http://www.mitf.org/public_e/archives/index.html

GSC: Standardization Advancing Global Communications

◆ **Overview of Advanced Wireless
Communications Study Committee**

*GSC: Standardization Advancing Global
Communications*

New Organizational Structure for Next Generation Wireless Communications Technologies



● Background

- International standardization activities for the future development of IMT-2000 and systems beyond IMT-2000 are currently undertaken by the ITU-R and other institutions.
- Activities on Broadband Wireless Access (BWA) systems have been accelerating both in Japan and abroad.
- The Study Group for Wireless Broadband Promotion under the Ministry of Internal Affairs and Communications says in its Final Report in December 2005 that it “expects to see further developments in systematic activities for the standardization and practical implementation of wireless broadband systems by private standardization bodies, etc.”

http://www.soumu.go.jp/joho_tsusin/eng/studygroupreport.html

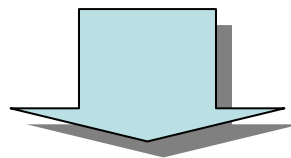

Establishment of

“Advanced Wireless Communications Study Committee”

GSC: Standardization Advancing Global Communications

Overview of Reorganization

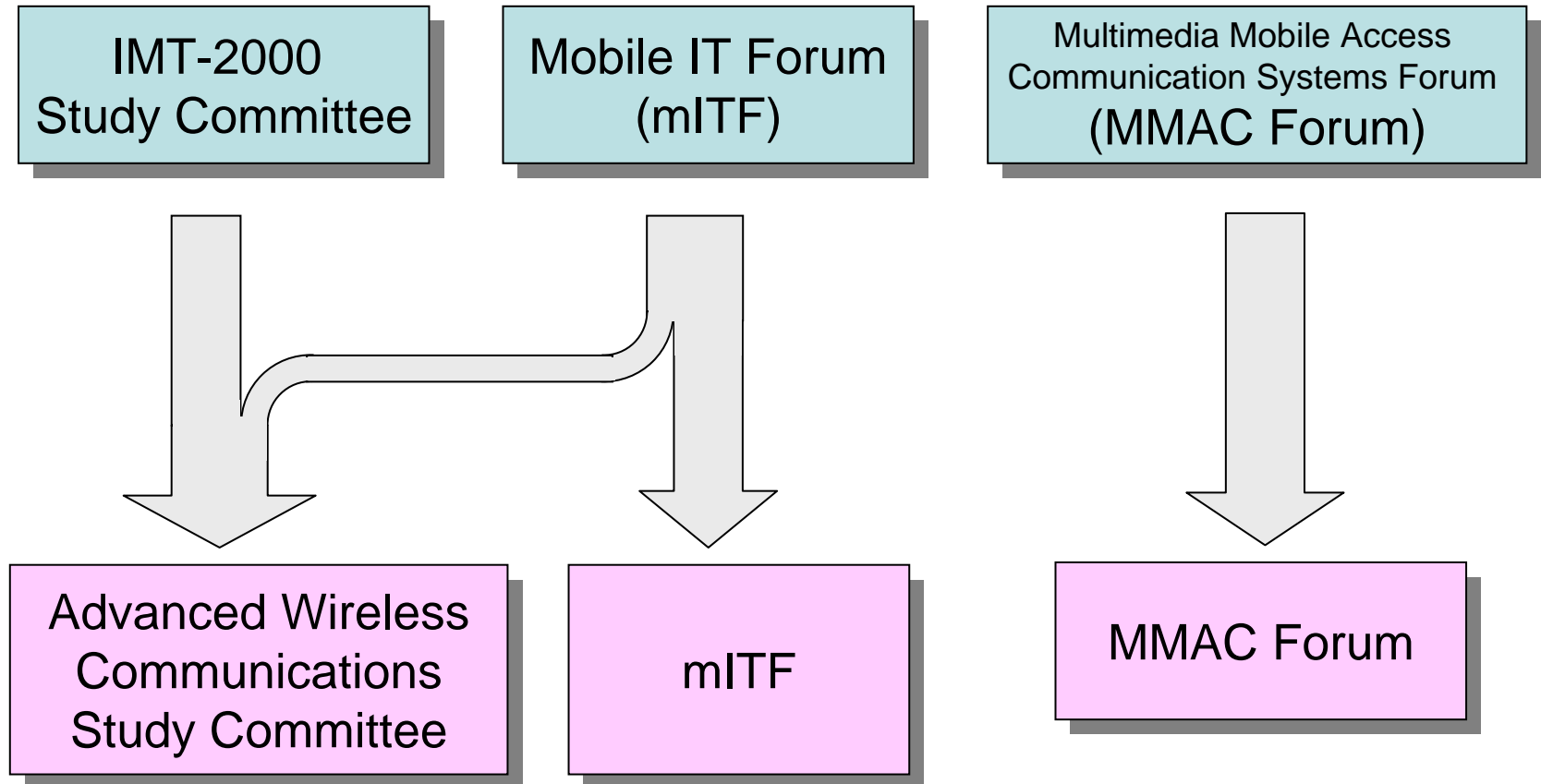

GSC: Standardization Advancing Global Communications

Overview of Advanced Wireless Communications Study Committee



● Responsibilities

- To perform the technical studies on advanced wireless communication systems in cooperation and coordination with other related institutions in Japan and overseas
- To contribute to their international standardization activities

● Structure of the Study Committee

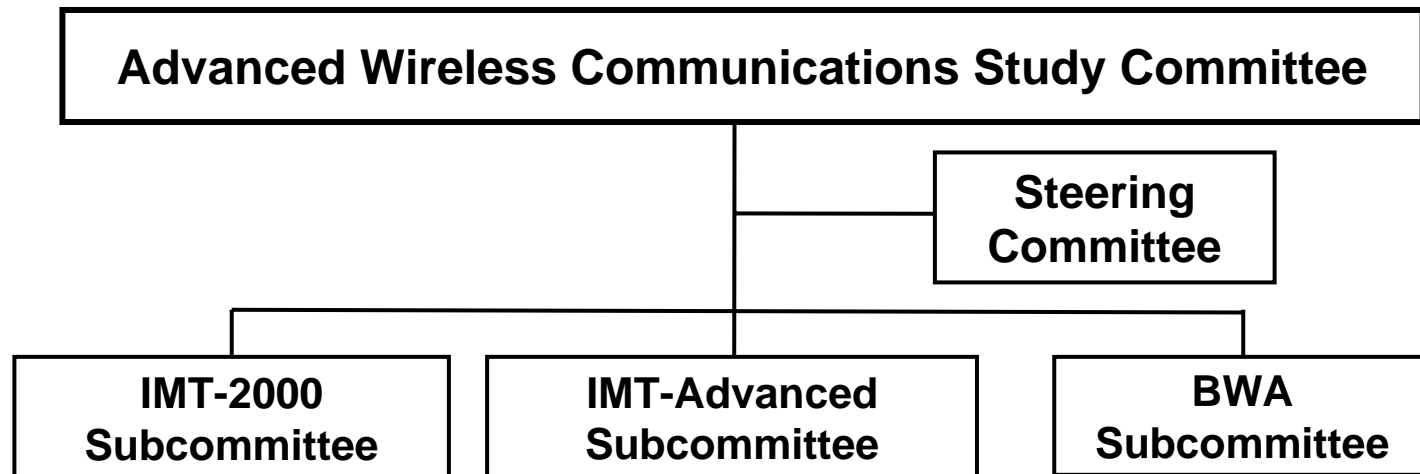

(Effective on 1st April 2006)

GSC: Standardization Advancing Global Communications

Organizational Structure of mITF before Reorganization

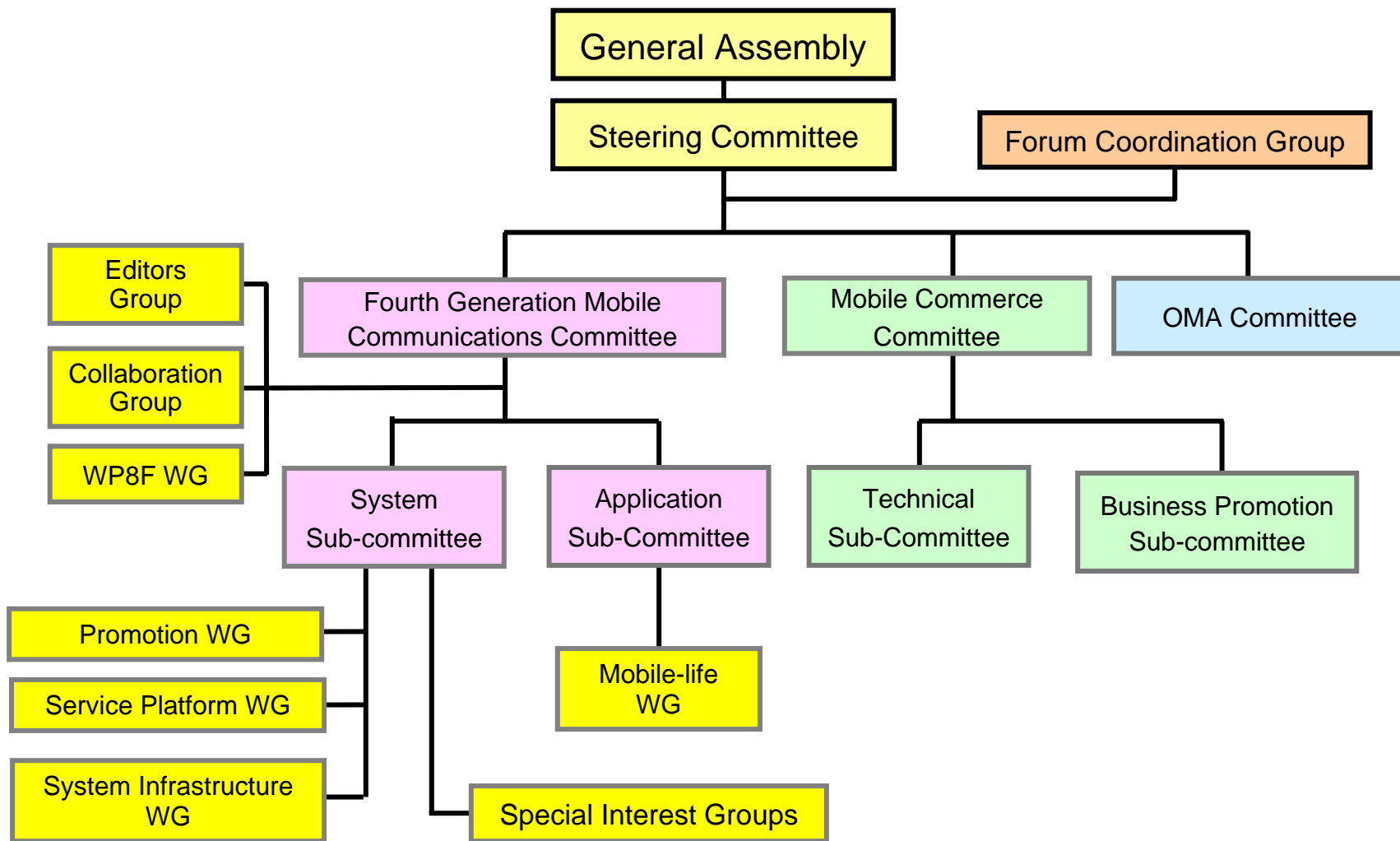

GSC: Standardization Advancing Global Communications

Organizational Structure of mITF after Reorganization

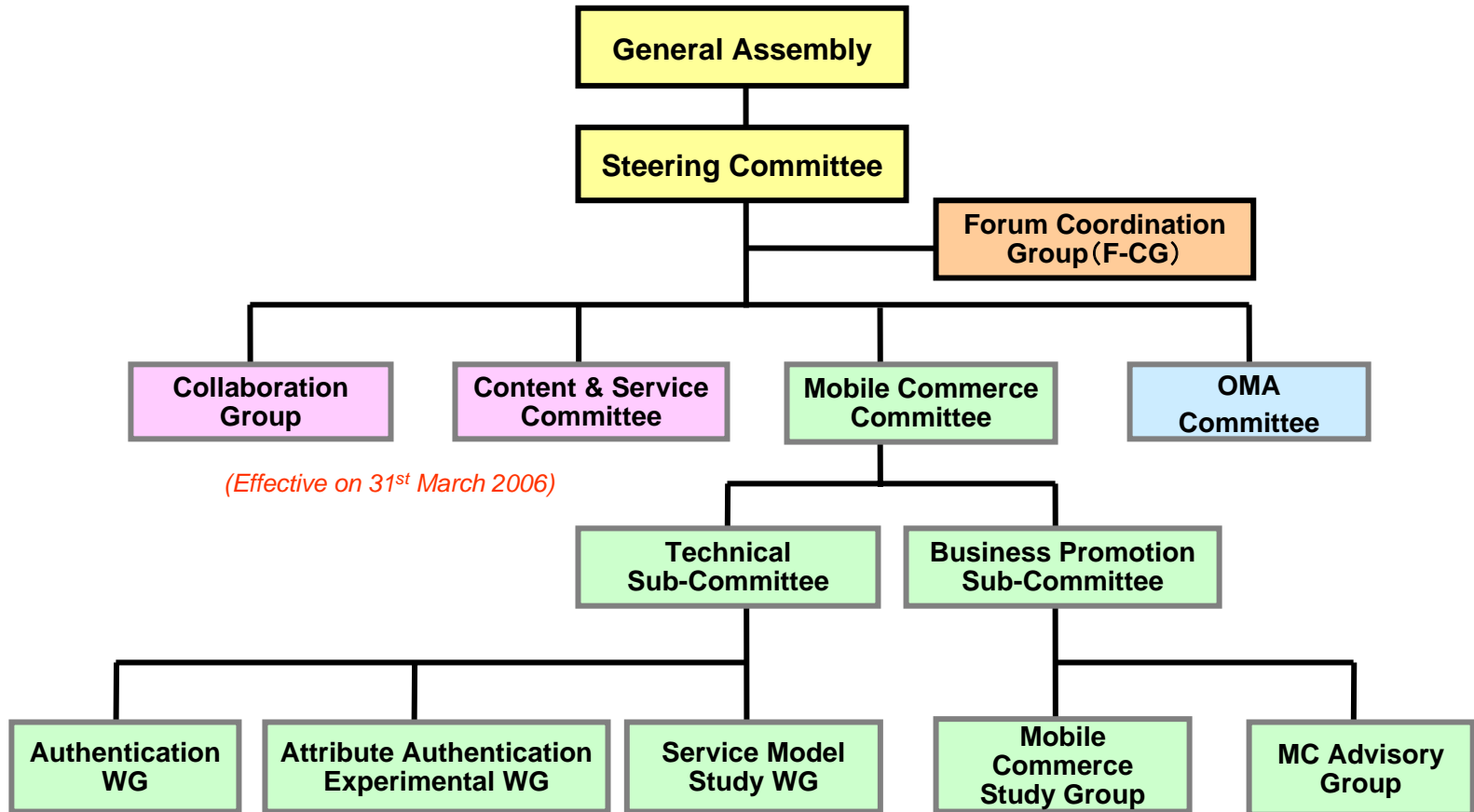

(The 2006 Workplan of mITF was approved at the 10th meeting of mITF Steering Committee held on 28th April 2006)

GSC: Standardization Advancing Global Communications

**Summary of Activities in GSC-11 on
Mapping Standards for “Systems beyond
IMT-2000”**

Summary of Activities in GSC-11



■ Input Contributions:

- CCSA presented “Evolution of TD-SCDMA” (gsc11_joint_15)
- ARIB presented “Activities on IMT-2000 and IMT-Advanced” (gsc11_joint_16r1)
- ETSI presented “3GPP LTE and SAE” (gsc11_joint_32)
- TTA proposed “Proposed Updated Resolution for IMT and related Technologies” (gsc11_joint_35)
- ITU proposed “Draft Resolution GSC-11/nn: Mapping Standards for IMT-Advanced” (gsc11_joint_48)

■ Main Outcome:

- Activities on enhancement of IMT-2000 and systems beyond IMT-2000 were active in 3GPPs and each PSO.
- Standardization activities on systems beyond IMT-2000 were updated in ITU-R WP8F.

■ Resolution on “Mapping Standards for Systems beyond IMT-2000” (gsc10_closing_09) should be updated

■ This Subject should be maintained as HIS for GSC#12

GSC: Standardization Advancing Global Communications